

1 DESCRIPTION

The NFS-640 Serial driver allows the FieldServer to record data from Notifier Onyx Series NFS-640, NFS2-640 and NFS-320 Fire Panels over RS-232. The FieldServer primarily acts as a Passive Client receiving unsolicited messages and updating the status of a Notifier Fire Alarm Panel. The FieldServer can actively request that the Notifier panel send the status of all points, devices and zones on a periodic basis.

The main purpose of this driver is to record the status of Fire Alarm System detectors and modules in a bit oriented Data Array. It is limited by the information that the Notifier Panel broadcasts in the form of text messages through its RS-232 communication port. The accuracy and timeliness of the data is therefore limited by the frequency of update messages that the Notifier Fire Panel issues, as well as the frequency of the read status requests that the FieldServer makes. The request for status of all points and zones occurs every 10 min by default; this period can be reduced to 5 min or increased to any value with no upper bounds.

The types of Notifier messages supported by this driver are summarized in this fact sheet. A detailed table showing each type of panel message the FieldServer recognizes and the effect that it has on the status of points in the data array is also presented. Finally, the device status to the data array mapping is also provided.

It is possible to connect through the CRT Port. The disadvantage of doing this is that the use of this port restricts the use of Notifier Networking, thus a fire panel connected to a Noti-Fire-Net will not be supported. If the NFS-640 or NFS2-640 CRT port is used, the FieldServer can actively request that the Notifier panel send the status of all points, devices and zones on a periodic basis. This status request occurs every 10 min by default; and can be reduced to 5 min or increased to any value with no upper bounds. Note that communication through this port does not equate to Port Supervision.

The panel must output messages in English. For Notifier 640 Onyx firmware with Spanish firmware (as sold in Mexico and other Central and South American markets) please refer to the fact sheet 'FST_DFS_Notifier_NFS-640 (Onyx)(Spanish)'

FieldServer Mode	Nodes	Comments
Client		Only one Notifier Panel may be connected to any single RS-232 FieldServer port.

2 FORMAL DRIVER TYPE

- Serial
- Client Only

3 COMPATIBILITY MATRIX

FieldServer Model	Compatible with this driver
FS-x2010	Yes
FS-x2011	Yes
FS-x25	Yes
FS-x30	Yes
FS-x40	Yes
SlotServer	Yes
ProtoCessor	Yes

4 CONNECTION INFORMATION

4.1 NFS-640 TB14 Printer Port; NFS2-640/NFS-320 TB12 Printer port

Connection type: RS-232 or RS-485 (with converter)
Baud Rates: 2400, 4800, **9600** (Vendor Limitation)
(Note 4800 is not applicable for NFS-640)
Data Bits: **7** (Vendor Limitation)
Stop Bits: **1** (Vendor Limitation)
Parity: **Even** (Vendor Limitation)
Multidrop Capability No

4.2 NFS-640 TB15 CRT Port; NFS2-640/NFS-320 TB12 CRT Port

Connection type: RS-232 or RS-485 (with converter)
Baud Rates: **9600** (Vendor Limitation)
Data Bits: **8** (Vendor Limitation)
Stop Bits: **1** (Vendor Limitation)
Parity: None (Vendor Limitation)
Multidrop Capability No

5 DEVICES TESTED

Device	Tested (Factory, Site)
NFS-640	Factory
NFS2-640	Factory

6 CONNECTION CONFIGURATIONS

The FieldServer is connected to the Notifier Onyx NFS-640 Panel as shown below. Configure the Notifier Onyx NFS-640 Panel according to manufacturer’s instructions. Note that the recommended connection through the printer port is depicted in the diagram. If preferred, connection can be made through the CRT port. . The default setting for the CRT port is off thus the port must be enabled before this driver can be used.

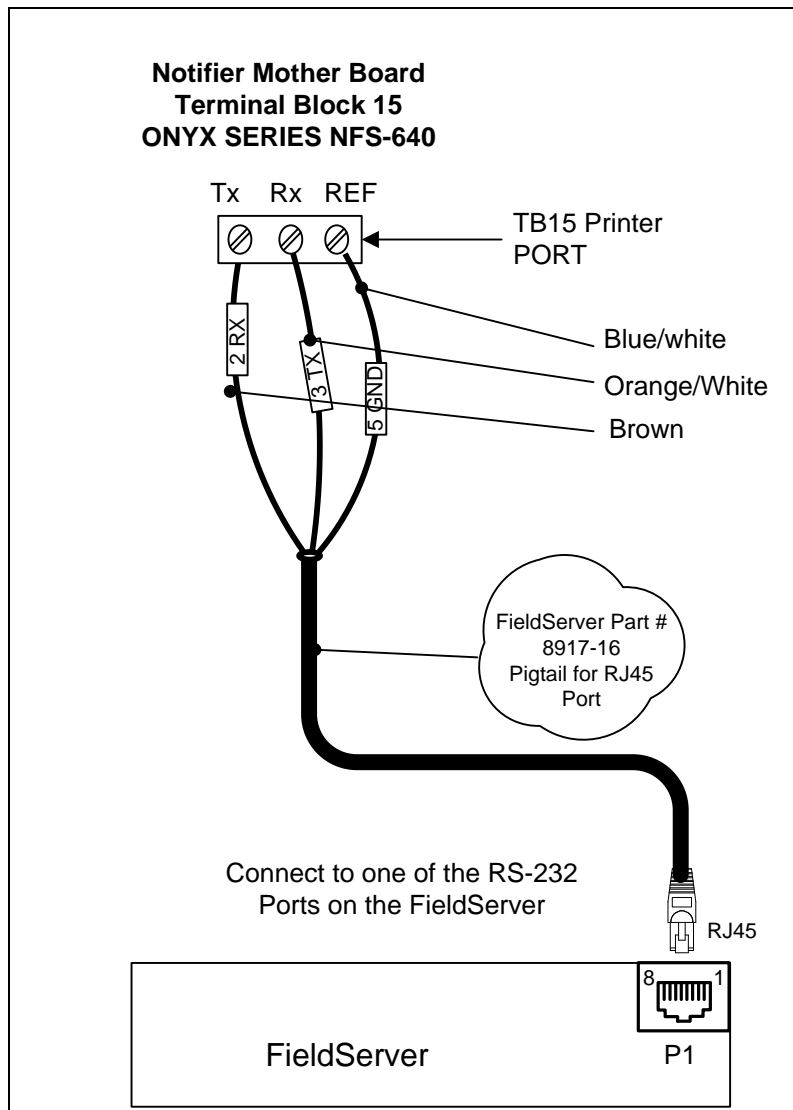

Figure 1: Diagram showing connection to the NFS-640 Printer Port.

The FieldServer is connected to the Notifier Onyx NFS2-640 Panel as shown below. Configure the Notifier Onyx NFS2-640 Panel according to manufacturer's instructions. Note that the recommended connection through the printer port is depicted in the diagram. If preferred, connection can be made through the CRT port.

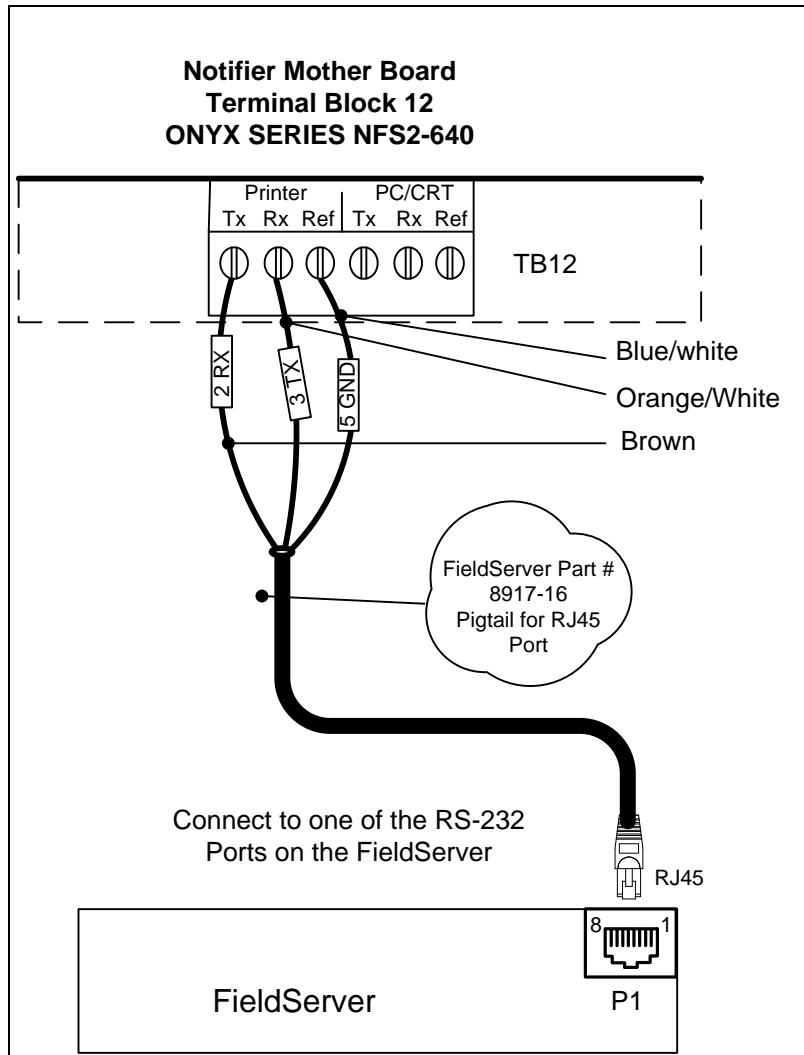

Figure 2: Diagram showing connection to the NFS2-640 Panel Printer Port

7 COMMUNICATIONS FUNCTIONS - SUPPORTED FUNCTIONS AT A GLANCE:

7.1 Message Types Supported

The purpose of this driver is to record the status of devices connected to the Notifier Panel by interpreting text messages sent to the printer or CRT port. Messages that do not directly pertain to device status are not reported. When a read point status is performed, points that have their status reported as TEST are regarded as being in a TROUBLE state. The following subset of event and read status messages is recognized:

Active Events	Read Point Status
SYSTEM NORMAL	ON/OFF
ALARM:	NORMAL
TROUBL/CLR TB	ALARM
ACTIVE/CLR ACT	TEST
PREALM/CLR PAL	TBL
DISABL/ENABLE	
TROUBL IN SYSTEM/CLR TB IN SYSTEM	
TEST	

7.2 Panel Status: Data Array Mapping

Parameter	Bits
Detector Alarm (loop 1) (loop 2) eg 2D001 -> 201	0-199 200-399
Zone Alarms (software) (special) (releasing) eg Z01 -> 801 F07 -> 907 R00 -> 910	800-899 900-909 910-919
Detector Trouble (loop 1) (loop 2)	1000-1199 1200-1399
Bell Circuit Trouble eg B01 -> 1891 B04 -> 1894	1890-1899
Detector Pre-Alarm (loop 1) (loop 2)	2300-2499 2500-2699
Module Disable (loop 1) (loop 2)	3100-3299 3300-3499
Panel Circuit Disable	3500-3589
On/Off status Panel Circuit	4000-4089
On/Off status Zone (software) (special) (releasing)	4100-4199 4200-4209 4210-4219

Parameter	Bits
Trouble status Zone (software) (special) (releasing)	4500-4599 4600-4609 4610-4619
Parameter	Bits
Module Alarm (loop1) (loop2)	400-599 600-799
Panel Circuit Trouble eg P1.1 -> 1811 P8.8 -> 1888	1800-1889
Module Trouble (loop 1) (loop 2)	1400-1599 1600-1799
Active Monitor Modules (loop 1) (loop 2)	1900-2099 2100-2299
Detector Disable (loop 1) (loop 2)	2700-2899 2900-3099
On/Off status Module (loop 1) (loop 2)	3600-3799 3800-3999
Bell Circuit Disable	3590-3599
On/Off status Bell Circuit	4090-4099
SystemTrouble 4499 = unknown system trouble 4300+ = listed system troubles	4300-4499
Disable Zone (software)	4700-4799

7.3 Zone Status:

Information about zone status will be recorded if incorporated with point status messages. Some messages (e.g. Trouble messages) do not contain zone status information.

If the device belongs to multiple zones, only the zone status of the first zone is reported. This limits the accuracy of zone data based on event generated messages, however, when the status is read, the zone status will be valid.

8 DRIVER LIMITATIONS & EXCLUSIONS

- This driver depends on the stability of the messages received by the printer/CRT ports. Should Notifier modify their message protocol, problems can be expected with this driver.
- The accuracy in recording the Notifier Panel status is dependent on synchronization with the FieldServer. Upon startup, the FieldServer polls the panel for the status of all points and is then fully synchronized. Event messages sent from the Notifier CRT port will also update the recorded status. Some status changes, e.g. zone information do not result in an explicit message to the port, therefore, the FieldServer's record may not be accurate until the next full read status request.
- When connected via the CRT port, the driver cannot support a fire panel connected to a Noti-Fire-Net, as the Network port (NUP port) cannot be used in conjunction with the CRT port.
- This driver does not support multi-dropped or networked Notifier panels.
- Active event messages such as ALARM: include primary zone information; however, a point device such as a detector or module can be associated with a listing of zones, of which only the first is identified in the message. The status of this zone will be recorded by the driver. To update the status of other zones, a read point status poll needs to be sent to the panel.
- Communication through the CRT port was not designed as a supervised port. Should Notifier wish to make this a supervised port, then this feature will need to be added to the FieldServer.
- Logic and evaluating equation status was not recorded by FieldServer's driver. These could be added at a later date.
- Percentage of detector alarms (smoke detectors for instance) is provided in detector status messages but was not implemented in this driver. If requested, this information can be provided as an addition at a later date