

1 DESCRIPTION

HACH Ultra Analytics (formerly Pacific Scientific Instruments) Standard Protocol FX (enhanced) – ENG110. Developed for interfaces to MetOne Particle Counters

The MetOne Particle Counter Serial driver allows the FieldServer to transfer data to and from devices over RS-232 or RS-485 using MetOne Particle Counter Serial protocol.

This driver is based on a specification called “Standard Protocol FX (enhanced)” ENG110 Revision A dated 1999 by Pacific Scientific Instruments. This protocol provides an interface to Particle Counters manufactured by HACH Ultra Analytics and labeled as METONE products. Pacific Scientific Instruments is a former name of Hach.

The primary purpose of the driver is to obtain the current particle counts, but it does allow for limited control and configuration of some counter parameters. While the driver provides Client and Server emulation, the Server side of the driver is intended to support FieldServer’s Quality Assurance program and is not intended to provide complete emulation of a MetOne Counter. Thus the Server side is not fully documented and is not supported. At a customer’s request the Server side functionality can be documented and enhanced. If you are interested in this functionality, then please contact FieldServer’s sales group.

When configured as a Client the driver can start/stop a unit from sampling, change its mode, set and get sample and hold times, startup or standby a unit and retrieve its current sample value. Whenever the driver stores a sample value, it will also store a timestamp of when the record was obtained.

In the configuration of the FieldServer each device is identified by specifying its device number then the sub-device code or port number and finally by a device type. The device type will be used to interpret the status byte obtained from the device.

For each configured node, each time the FieldServer sends a message to the device it will select the device (and the select the sub-device or port if specified) and then the message will be sent. If the most recent message sent was sent to the device, the driver will do the selection to ensure the correct device response. The delay between messages is configurable.

When the current record is read from a device then the driver will store the data extracted from the response in a range of consecutive Data Array elements so that these values can be served to another protocol. Even though the record data contains a time stamp, the driver will make its own time stamp for new data. If there is no current record the driver will not update the data.

If the response is invalid in any way – invalid characters or invalid checksum the driver will ignore the message and not store any data.

Max Nodes Supported

FieldServer mode	Nodes	Comments
Client	1	There can only be one Client node per FieldServer port. The driver can poll any number of Server nodes provided that they comply with the vendors numbering requirements
Server		Driver as a Server is not documented or supported. Used only for QA purposes.

2 FORMAL DRIVER TYPE

Serial

Client Only

3 COMPATIBILITY MATRIX

FieldServer Model	Compatible with this driver
FS-x2010	Yes
FS-x2011	Yes
FSx25	No
FS-x30	Yes
FS-x40	Yes
SlotServer	No
ProtoCessor	No
ProtoNode	No

4 CONNECTION INFORMATION

Connection type: RS-232 and/or RS-485 (Two wire, Half-Duplex)
Baud Rates: 9600 (Vendor limitation).
Data Bits: 8 (Vendor limitation)
Stop Bits: 1 (Vendor limitation)
Parity: None (Vendor limitation)
Hardware interface: None
Multidrop Capability Yes

5 DEVICES TESTED

Device	Tested (FACTORY, SITE)
R4803 Remote Particle Counter	SITE
2100 Particle Counter with 2432 Manifold with 32 locations.	SITE

6 CONNECTION CONFIGURATIONS

6.1 Connection to 2100 Particle Counter

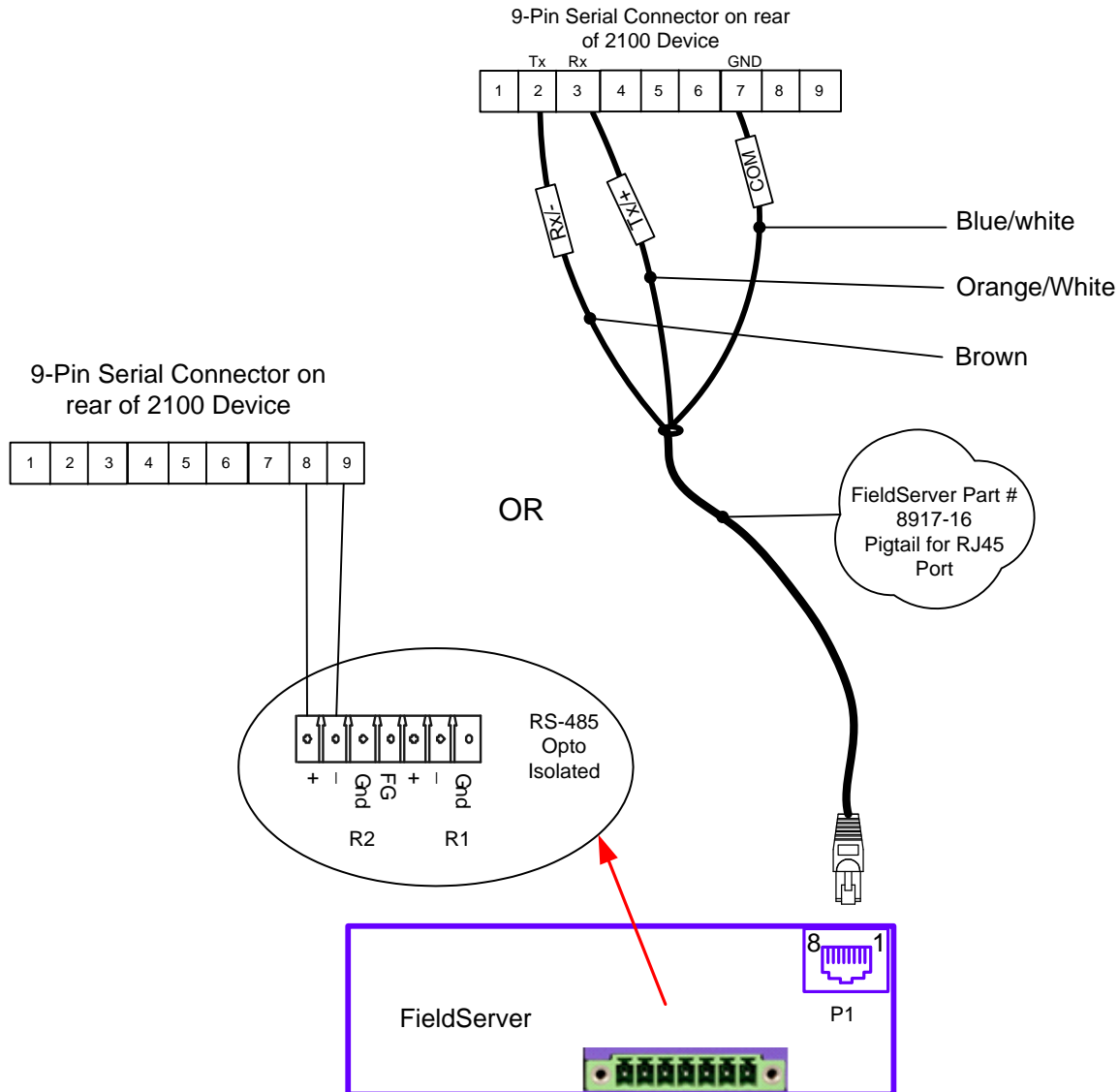

Connector Pinouts

FS Function	RJ45 Pin#	2100 Pin	2100 Function	Color
RX	1	2	Tx	Brown
Tx	2	3	Rx	Orange/White
COM	3	7	GND	Blue/White

6.2 Connection to 4308 Particle Counter

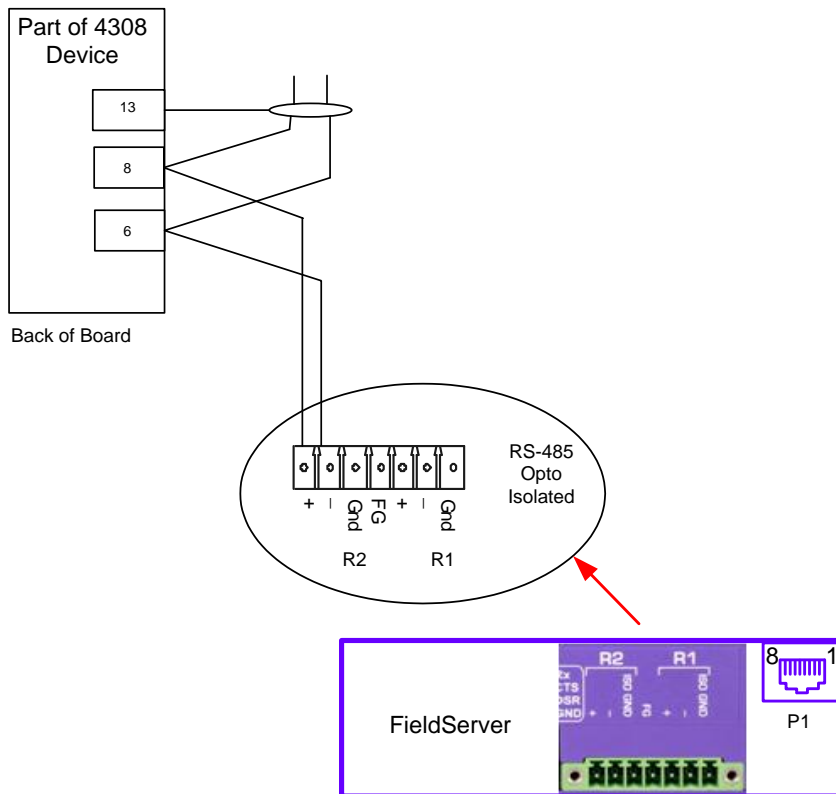

6.3 Connection Notes

- The 2100 Device auto configures its serial port based on the pins connected. There is no explicit setting or selector for RS-232/RS-485
- Ensure other pins are not connected.
- The FS-8917-16 cable is not needed for RS-485 on the X30 and X40 only.

7 COMMUNICATIONS FUNCTIONS - SUPPORTED FUNCTIONS AT A GLANCE:

Function	Supported	Notes
Send Buffered Records	No	We will always read the current record
Send Current Record	Yes	
Clear Buffer	No	
Query Number of Records	No	
EPROM Number	No	
View Hold Time	Yes	
Program Hold Time	Yes	
View Sample Time	Yes	
Program Sample Time	Yes	
Query Mode	Yes	
Re-Transmit Record	No	
Identify Type	No	
Universal Device Select	No	
Protocol Version	No	
Device Select	Yes	
Sub-Device Select	Yes	
Set to Auto Sample Mode	Yes	
Set to Manual Sample Mode	Yes	
Quick Start Counting	No	
Start Counting	Yes	
Stop Counting	Yes	
Set Active Mode	Yes	Powers up unit
Set Standby Mode	Yes	Powers down unit
Universal Auto Sample Mode	No	No Universal commands implemented
Universal Manual Sample Mode	No	
Universal Clear Buffer	No	
Universal Quick Start Count	No	
Universal Start Count	No	
Universal Stop Count	No	
Universal Set Active Mode	No	
Universal Set Standby Mode	No	

7.1 Unsupported Devices or Protocol Options

The driver cannot be used to control the MetOne 2432 Manifold.

The driver expects that the Particle counters have been correctly configured – it cannot be used to configure the devices. The 2100 Counter in particular must be configured to process each port of interest. The driver does not command the sampling, it only retrieves the data.