

1 DESCRIPTION

This document describes the FieldServer driver used to transfer data between a FieldServer and MicroTech® controllers. Such transfers are done using the controller's Data Terminal Communications Protocol. In this document the protocol is referred to as the McQuay Micro Tech Open Protocol. The McQuay MicroTech® Open Protocol driver allows the FieldServer to transfer data to and from devices over either RS-232 or RS-485 using McQuay MicroTech® Open Protocol. The FieldServer can emulate either a Server or Client.

In emulating a client the driver allows the FieldServer to request 'Everything' from the McQuay device as well as a number of advanced options which allow specific fields to be read or written and device scaling to be applied.

In emulating a server the driver provides basic functionality only, by providing an emulation of the byte memory of a device and responding to read and write requests.

Please refer to Section 7.3-Unsupported Functions and Data Types.

FieldServer Mode	Nodes	Comments
Client	1 (255)	If an OPM is present, up to 255 controllers can be linked through one serial port, otherwise only one node is supported per port. One OPM can be connected per port.
Server	n/a	

2 FORMAL DRIVER TYPE

Serial
Client or Server

3 COMPATIBILITY MATRIX

FieldServer Model	Compatible with this driver
FS-x2010	Yes
FS-x2011	Yes
FSx25	Yes
FS-x30	Yes
FS-x40	Yes
SlotServer	Yes
ProtoCessor	Yes
ProtoNode	Yes

4 CONNECTION INFORMATION

Connection type: RJ45 Pigtail for RS-232/RS-485
Baud Rates: 300, 1200, 2400, 4800 and 9600 baud (Vendor limitation).
Data Bits: 7 (Vendor limitation)
Stop Bits: 1 (Vendor Limitation)
Parity: Even
Multidrop Capability: Yes

5 DEVICES TESTED

Device	Tested (FACTORY, SITE)
200CFC 200 Series Centrifugal Chiller	Site
RPS105CLA	Site
SCU 5060002J	Site
RMC-E01	Site
PEH-063-DCBC	Site
PFH087- BCCB	Site
PEH126 –BCBB	Site
CSG3S04G	Site
CSG3S04J	Site
Vintage Flooded Screw Chiller	Site
Self-Contained Air Conditioning Controller	Site
OPM	Site

6 CONNECTION CONFIGURATIONS

The FieldServer is connected to the McQuay device as shown below. Configure the McQuay device according to manufacturer's instructions.

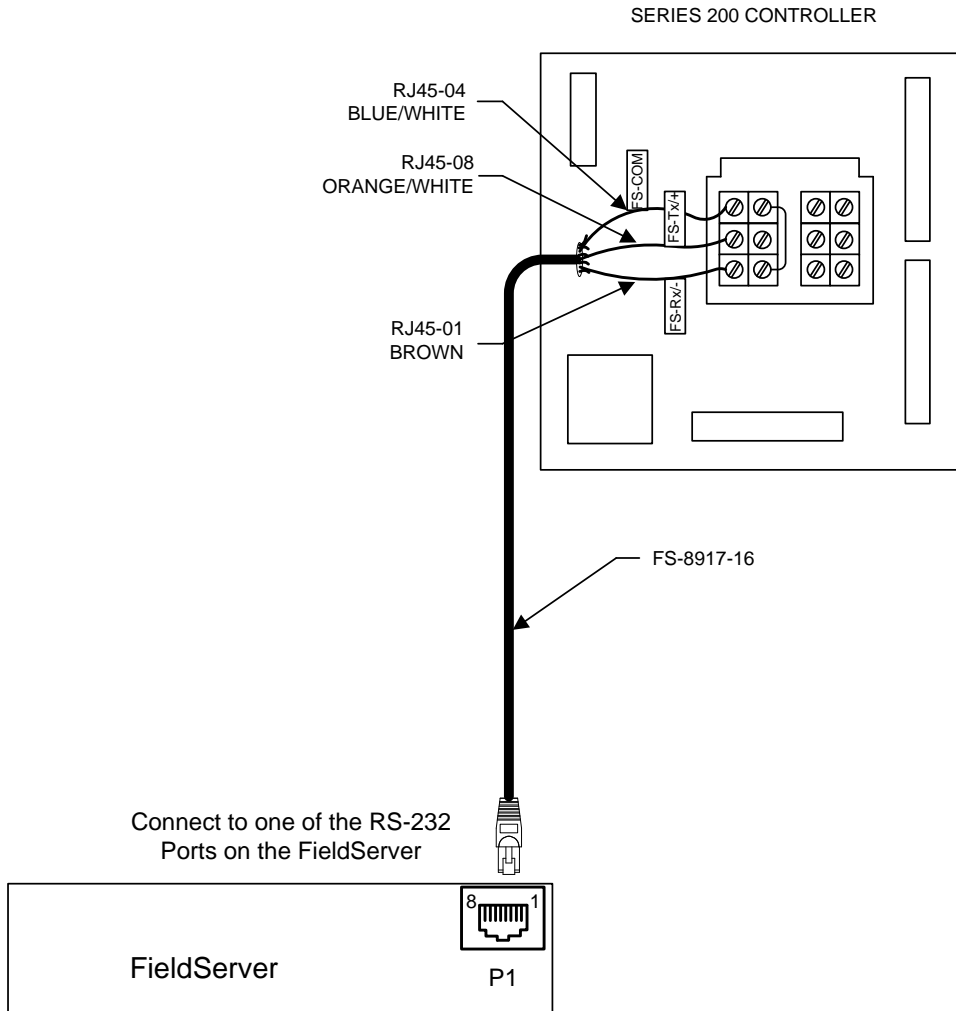

7 COMMUNICATIONS FUNCTIONS - SUPPORTED FUNCTIONS AT A GLANCE:

7.1 Functions:

Function	Description
Read	Reads a single data field.
Write	Writes a single data field to the McQuay device. Only some data fields in the McQuay device may be written to.

7.2 Data Types Supported

FieldServer Data Type	Description (or Device Data Type)
200CFC - 200 Series Centrifugal Chiller	Data fields of interest may be specified using the data field name or by specifying the 'address/memory location'
100CFC - 100 Series Centrifugal Chiller	
001ASC - Air Screw Chiller	
000SCU - Self Contained Unit	
0050RPC - Reciprocating Chiller	
Other devices	Any other device which supports McQuay's Open Protocol™ Data Communications Information Packet Version 1.4 April, 1996 can be read or written using this driver. When reading or writing these 'other' devices, the data fields of interest are specified using the 'address/memory location' specified as a hexadecimal number (obtained for the product specification.) At a customer's request the driver can be updated to allow the fields to be specified by their field names.

7.3 Unsupported Functions and Data Types

- Arising from a feature of the McQuay MicroTech® Open Protocol is the peculiarity that when a multi-byte value is written to a McQuay device, the write is done one byte at a time (one byte of data can be transferred per poll/response message pair) allowing for the possibility that the multi byte value is only partially correct until all the messages have been completed.
- The vendor equipment is limited to a maximum of 9600 baud. Given that each message packet can only transfer one byte of data and that some data of interest is multi-byte, users of this protocol should expect low data transfer rates.
- Port expansion is not supported for this driver.
- Each MicroTech® controller is shipped from the factory with a unique job site password. The passwords are provided by the McQuay International representative at the time of startup. The driver does not validate passwords when configured as a Server. This means that requests to read or write data will succeed even if the password supplied with the request is incorrect.

A document identified as *Ed15050 MicroTech Network Operations* contains important information regarding the connection requirements of 3rd party equipment such as the FieldServer to a Microtech network. The document also defines a number of limitations for such connections. The following quotations from this document outline some of this information.

PC Connection: The PC connection to a MicroTech controller is through an available port A that is configured as TTY. It is best to connect the PC to a level-1 controller because data transmission is the fastest. However, a PC can be connected to any level-2 controller that does not have level-3 controllers connected to it or to any MicroTech level-3 controller. Regardless of where you connect the PC, you have access to the entire network.

You can connect two or more PCs to the network, but only one PC can be connected to a particular controller. The PC that you use most often should be connected to the level-1 controller for best performance. For example, you may have one PC that you use on site and another PC that you use off site. In this situation, you may want to connect the on-site PC to the level-1 controller and the modem for the off-site PC to a level-2 or level-3 controller.

If a PC is connected to a level-2 controller, a level-1 controller must poll that level-2 controller connected to the PC so that the PC has access to the entire network. Defining a level-2 controller in the level-1 controller Server list causes the level-1 controller to poll the level-2 controller.

Port Configuration: The communications port that the PC is connected to must be configured as a TTY port. The default port configuration for most MicroTech controllers sets port A as TTY. The port configuration is a software setting.

A separate software setting defines the communications rate of each port. In most controllers, the default rate is 9600 bps.

TTY: A TTY port is used to connect a PC for monitoring purposes. It uses the RS-232C interface standard and the Data Terminal Communications protocol.

The following quote from “MicroTech® Data Terminal Communication Packets, Open Protocol™ Data Communications Information Packet ” highlights an important limitation of the protocol.

Data terminal communications may be sent via RS-232C or RS-485. Regardless of the electrical standard used for communications, this protocol is a single ended type (i.e., communications to one MicroTech controller maximum).

7.4 McQuay Equipment Types recognized by the driver.

Code	Description
200CFC	200 Series Centrifugal Chiller
100CFC	100 Series Centrifugal Chiller
001ASC	Air Screw Chiller
000SCU	Self Contained Unit
0050RPC	Reciprocating Chiller