

1 DESCRIPTION

The Gamewell FCI E3 Series System Control Units are manufactured by Fire Control Instruments. A Gamewell FCI-E3 Panel with an enabled serial port can transmit data to a FieldServer which can, in turn, make the data available to other devices including those which communicate using different protocols. Messages received from the E3 are analyzed and are then either discarded or used to update the FieldServer's internal Data Arrays depending on the configuration of the FieldServer. Once stored in the FieldServer the data is available to be read or written using other protocols.

This passive Client driver does not poll for data, nor does it send data or commands to the E3, thus it cannot be used to acknowledge, silence or reset alarms and other events.

No automatic panel data synchronization technique exists. The data in the FieldServer and the panel status have to be synchronized manually. This typically requires a panel reset.

The driver can process messages from networked panels. The driver connects to the main panel. Subsidiary panels are configured to send event data to the main panel which then sends messages to the FieldServer. Node information is sent in the line preceding the event and the driver uses this to determine the panel at which the event originated and to store data appropriately.

The driver provides both Client and Server emulation. The Server side of the driver is intended to support FieldServer's Quality Assurance program and is not intended to provide complete emulation of an E3 and is thus not fully documented. Should you require the Server side functionality to be documented and enhanced, please contact FieldServer's sales group..

FieldServer Mode	Nodes	Comments
Client	1	1 Node per serial port. If there is more than one alarm panel they can be networked and configured to send event data to the primary panel. The driver can process messages which identify the node of origin.

2 FORMAL DRIVER TYPE

- Serial
- Passive Client

3 COMPATIBILITY MATRIX

FieldServer Model	Compatible with this driver
FS-x2010	Yes
FS-x2011	Yes
FSx25	Yes
FS-x30	Yes
FS-x40	Yes
SlotServer	Yes
ProtoCessor	Yes
ProtoNode	Yes



Fire Control Instruments – Gamewell FCI- E3 Series

Doc. No.

Ver: 1.02

FS-8700-132

Rev: 3

4 CONNECTION INFORMATION

Connection type: RS-232
Baud Rates: 9600, 57600 (Vendor Limitation)
Data Bits: 8 (Vendor Limitation)
Stop Bits: 1 (Vendor Limitation)
Parity: None (Vendor Limitation)
Multidrop Capability: No

5 DEVICES TESTED

Device	Tested (FACTORY, SITE)
Gamewell FCI-E3 Series	SITE (FCI Distributor)

6 CONNECTION CONFIGURATIONS

The FieldServer is connected to the Gamewell FCI-E3 panel as shown in the connection drawing.

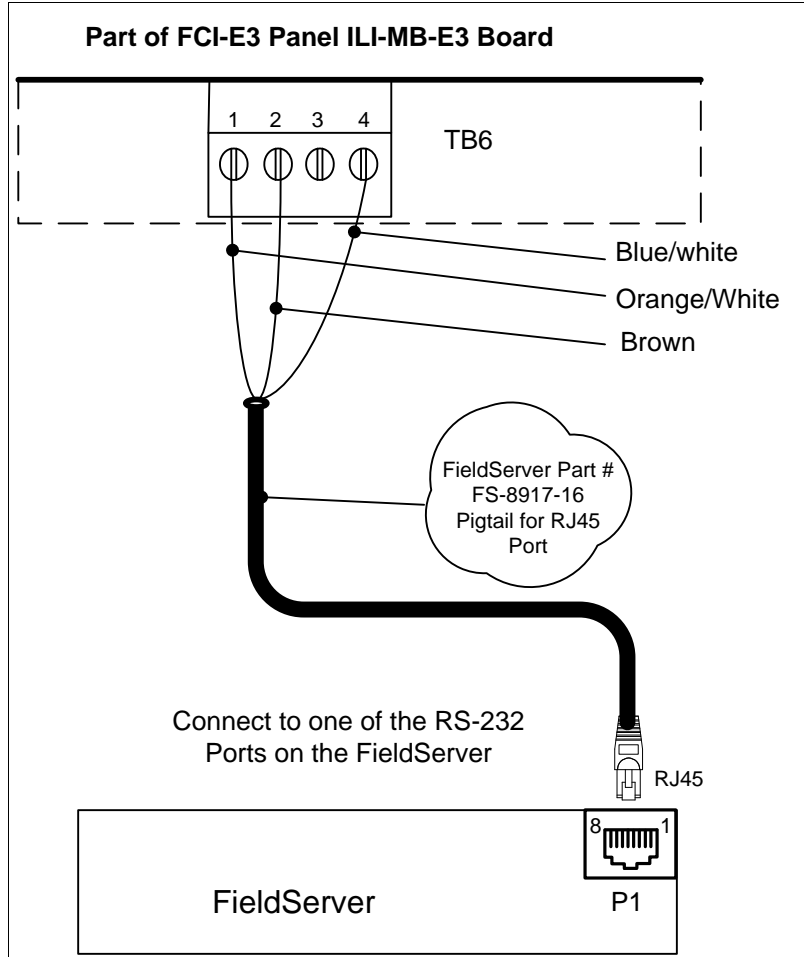

Connector Pinouts

Wire Color	RJ-45		Gamewell FCI-E3	
	Pin	Signal	Signal	Pin
Brown	1	Rx	+ve	2
White/Orange	8	Tx	-ve	1
Blue/white	5	GND	Signal Common Reference	4

7 COMMUNICATIONS FUNCTIONS - SUPPORTED FUNCTIONS AT A GLANCE:

The driver listens passively for messages from the 'E3' serial interface. The driver assumes that each message relates either to the 'E3' or a single point.

A point is considered to be a zone, relay output, loop, ALU sensor or ALU Module.

If the driver has not been configured to store data for particular points then messages containing status information for those points will be ignored.

The driver may be configured store data in any combination of the following. Multiple methods may be used for each point.

- Store the type of event (by storing an index number – Zero for restore) or
- Store a '1' when an event occurs and a zero when an event is restored or
- Recognize only specified events for a point. Example. Configure driver to store alarm events for point L1M03 at one location and store trouble events at others. The selection is limited to Alarm, Fault, Trouble. All other events are captured as 'Other'.

New event types can be added to the driver using the configuration file. This feature may allow the driver to capture new events when the FCI panel firmware is updated to generate new event types.

Manual synchronization with the FieldServer is required. Ther reset button on the panel transmits a reset message to the FieldServer, which clears the data in the FieldServer. After a reset the panel sends messages to report all abnormal states. When all these messages have been processed the FieldServer and panel will be synchronized. This process can be repeated at any time.

7.1 Unsupported Devices or Protocol Options

Item	Details
Event Date and time, Device Type Identifier (Signal Ckt 1, Municipal Circuit etc) , Unit Identifier ('E3', QZU etc), User define Label	This data is discarded.