



A Sierra Monitor Company

**Driver Manual**  
**(Supplement to the FieldServer Instruction Manual)**

**FS-8700-97 Lutron Machine**

**APPLICABILITY & EFFECTIVITY**

**Effective for all systems manufactured after November 2011**

Driver Version: 1.04  
Document Revision: 1

**TABLE OF CONTENTS**

**1 Lutron Machine Description ..... 3**

**2 Driver Scope of Supply ..... 3**

2.1 Supplied by FieldServer Technologies for this driver ..... 3

2.2 Provided by the Supplier of 3<sup>rd</sup> Party Equipment ..... 3

2.2.1 *Hardware* ..... 3

2.2.2 *Required 3<sup>rd</sup> Party Software* ..... 3

2.2.3 *Required 3<sup>rd</sup> Party Configuration* ..... 3

**3 Hardware Connections ..... 4**

3.1 Pinouts ..... 5

**4 Data Array Parameters ..... 6**

**5 Configuring the FieldServer as a Lutron Machine Client ..... 7**

5.1 Client Side Connection Parameters ..... 7

5.2 Client Side Node Parameters ..... 8

5.3 Client Side Map Descriptors ..... 8

5.3.1 *FieldServer Related Map Descriptor Parameters* ..... 8

5.3.2 *Driver Related Map Descriptor Parameters* ..... 9

5.3.3 *Timing Parameters* ..... 9

5.3.4 *Map Descriptor Example 1 - Binary Output (Zone and Area Machine)* ..... 10

5.3.5 *Map Descriptor Example 2 - Binary Input (Zone Machine)* ..... 11

5.3.6 *Map Descriptor Example 3 - Binary Input (Area Machine)* ..... 12

5.3.7 *Map Descriptor Example 4 - Analog Output 1 (Area Machine)* ..... 13

5.3.8 *Map Descriptor Example 5 - Analog Output 1 (Zone Machine)* ..... 14

5.3.9 *Map Descriptor Example 6 - Analog Output 2 (Zone and Area Machine)* ..... 15

5.3.10 *Map Descriptor Example 7 - Analog Input (Area Machine)* ..... 17

5.3.11 *Map Descriptor Example 7 - Analog Input (Area Machine)* ..... 18

5.3.12 *Map Descriptor Example 8 - Analog Input (Zone Machine)* ..... 19

5.3.13 *Map Descriptor Example 9 - Multistate Output (Zone and Area Machine)* ..... 20

5.3.14 *Map Descriptor Example 10 - Binary Value (Zone and Area Machine)* ..... 22

5.3.15 *Map Descriptor Example 11 - Analog Value (Zone and Area Machine)* ..... 23

**Appendix A. Useful Features ..... 24**

Appendix A.1. Map Descriptor Functions ..... 24

## 1 LUTRON MACHINE DESCRIPTION

The Lutron Machine driver allows the FieldServer to transfer data to and from devices over RS-232 using Lutron eLumen protocol. The FieldServer can emulate either a Server or Client, although the Lutron Machine driver is only available in Client configuration. Server drivers are for FieldServer testing purposes only.

### Max Nodes Supported

FieldServer Mode	Nodes	Comments
Client	1	Only one Lutron Machine driver Client node is able to be connected to a Lutron eLumen panel.
Server	1	One BACNet IP node provides an interface to the Lutron eLumen panel.

The Lutron Grafik Machine Zone/Area Machine driver, hereafter simply referred to as the Lutron Machine driver, provides a BACNet IP interface to a Lutron eLumen panel. The driver can be configured to represent zones or areas as used in the Lutron eLumen panel. The FieldServer acts as both Client and Server to provide BACNet objects to an external BACNet Client. In Server mode, the FieldServer collects data from the eLumen panel and holds the data ready for reads from an external BACNet Client. In Client mode, the FieldServer executes pre-defined commands on the eLumen panel, for example, running scripts.

## 2 DRIVER SCOPE OF SUPPLY

### 2.1 Supplied by FieldServer Technologies for this driver

FieldServer Technologies PART #	Description
FS-8915-10	UTP cable (7 foot) for RS-232 use
FS-8917-03	RJ45 to DB9F connector adapter

### 2.2 Provided by the Supplier of 3<sup>rd</sup> Party Equipment

#### 2.2.1 Hardware

Part #	Description
	Lutron eLumen Panel

#### 2.2.2 Required 3<sup>rd</sup> Party Software

An external BACnet IP Client to interface to the Lutron Machine on the FieldServer.

#### 2.2.3 Required 3<sup>rd</sup> Party Configuration

BACnet IP Client must be set up to access FieldServer over the network.

### 3 HARDWARE CONNECTIONS

The FieldServer is connected to the Lutron eLumen panel as shown in the connection drawing below:

Configure the eLumen panel according to manufacturer's instructions.

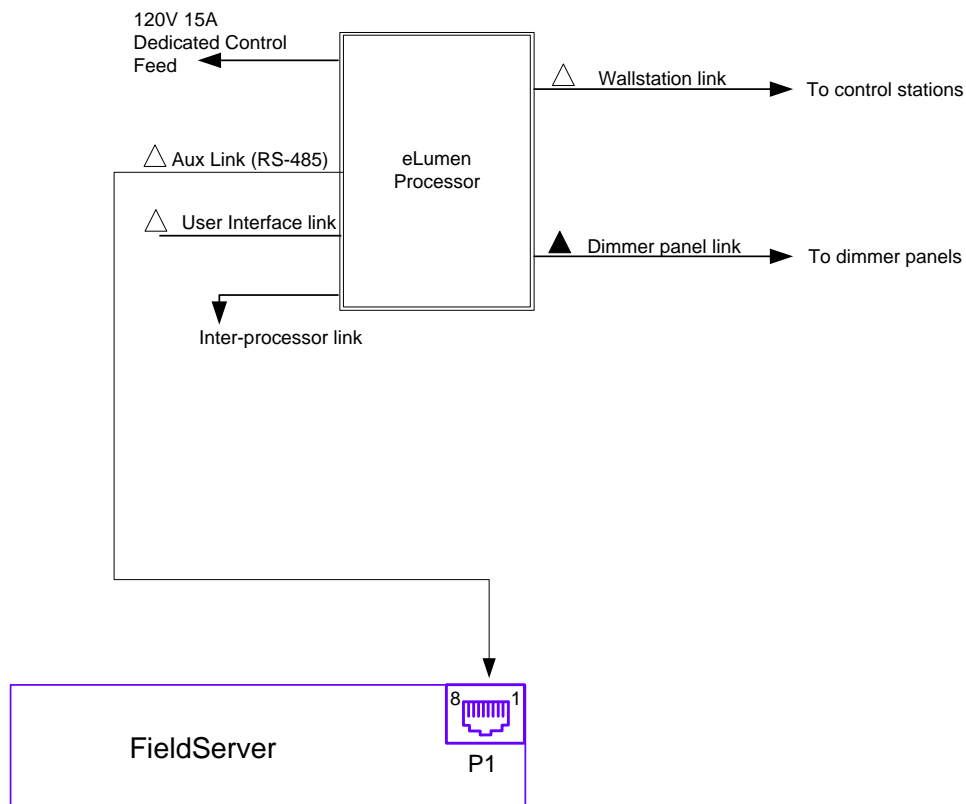
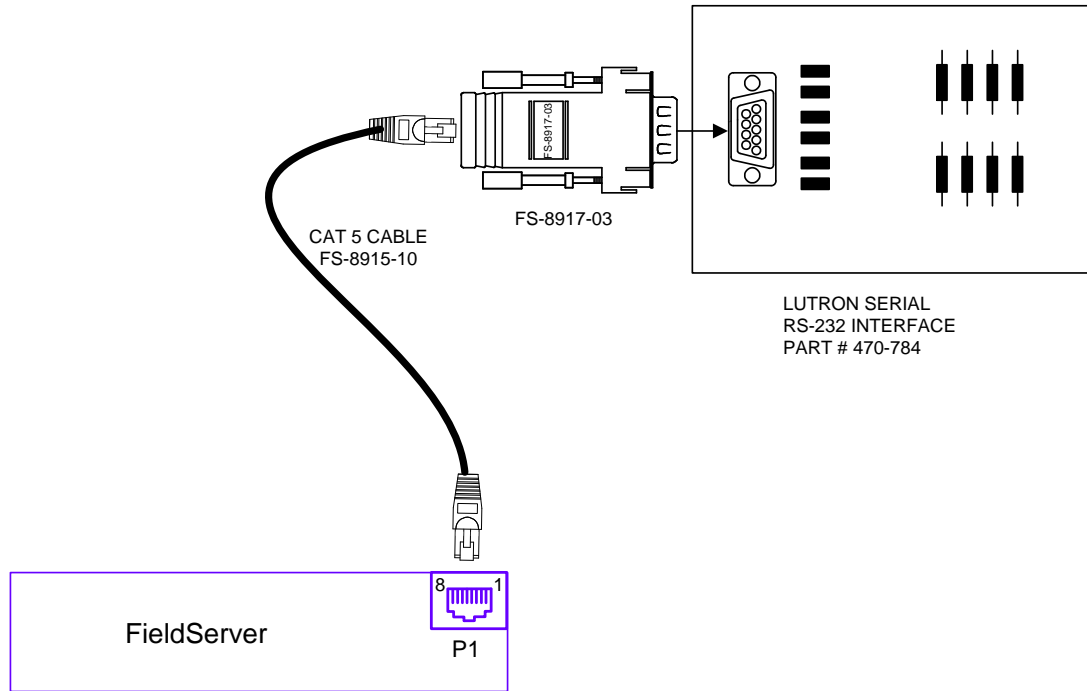

### 3.1 Pinouts

Function	From	To	Color
RX	RJ45-01	DB9F-02	Red
CTS		DB9M-08	White
GND	RJ45-04	DB9F-05	Black
RTS		DB9F-07	Brown
TX	RJ45-08	DB9M-03	Green

**4 DATA ARRAY PARAMETERS**

Data Arrays are “protocol neutral” data buffers for storage of data to be passed between protocols. It is necessary to declare the data format of each of the Data Arrays to facilitate correct storage of the relevant data.

Section Title		
Data_Arrays		
Column Title	Function	Legal Values
Data_Array_Name	Provide name for Data Array	Up to 15 alphanumeric characters
Data_Array_Format	Provide data format. Each Data Array can only take on one format.	Float, Bit, UInt16, Sint16, Byte,
Data_Array_Length	Number of Data Objects. Must be larger than the data storage area required by the Map Descriptors for the data being placed in this array.	1-10,000

**Example**

```
// Data Arrays
Data_Arrays
Data_Array_Name , Data_Array_Format , Data_Array_Length
Binary_Output , Bit , 512
Binary_Input , Bit , 512
Analog_Output , UInt16 , 512
Analog_Input , UInt16 , 512
```

## 5 CONFIGURING THE FIELDSEVER AS A LUTRON MACHINE CLIENT

For a detailed discussion on FieldServer configuration, please refer to the FieldServer instruction manual. The information that follows describes how to expand upon the factory defaults provided in the configuration files included with the FieldServer (See “.csv” sample files provided with the FieldServer).

This section documents and describes the parameters necessary for configuring the FieldServer to communicate with a Lutron eLumen panel.

The configuration file tells the FieldServer about its interfaces, and the routing of data required. In order to enable the FieldServer for Lutron eLumen communications, the driver independent FieldServer buffers need to be declared in the “Data Arrays” section, the destination device addresses need to be declared in the “Client Side Nodes” section, and the data required from the servers needs to be mapped in the “Client Side Map Descriptors” section. Details on how to do this can be found below.

Note that in the tables, \* indicates an optional parameter, with the bold legal value being the default.

### 5.1 Client Side Connection Parameters

Section Title		
Connections		
Column Title	Function	Legal Values
Port	Specify which port the device is connected to the FieldServer	P1-P8, R1-R2 <sup>1</sup>
Protocol	Specify protocol used	eLumen
Baud*	Specify baud rate	<b>9600</b> (Vendor limitation)
Parity*	Specify parity	<b>None</b> (Vendor limitation)
Data_Bits*	Specify data bits	<b>8</b> (Vendor limitation)
Stop_Bits*	Specify stop bits	<b>1</b> (Vendor limitation)
Poll_Delay*	Time between internal polls	0-32000 seconds, 1 second

#### Example

```
// Client Side Connections

Connections
Port , Protocol , Baud , Parity , Poll_Delay
P1 , eLumen , 9600 , None , 0.100s
```

<sup>1</sup> Not all ports shown are necessarily supported by the hardware. Consult the appropriate Instruction manual for details of the ports available on specific hardware.

## 5.2 Client Side Node Parameters

Section Title		
Nodes		
Column Title	Function	Legal Values
Node_Name	Provide name for node	Up to 32 alphanumeric characters
Node_ID	The eLumen processor address. Only decimal values are allowed: e.g. 11 hex must be entered as 17.	0-255
Protocol	Specify protocol used	eLumen
Connection	Specify which port the device is connected to the FieldServer	P1-P8, R1-R2 <sup>1</sup>
Node_Type	Specifies the eLumen command and data format	Hex, Decimal

### Example

```
// Client Side Nodes

Nodes
Node_Name , Node_ID , Protocol , Port , Node_Type
LUT_GRF6_0 , 17 , eLumen , P1 , Hex
```

## 5.3 Client Side Map Descriptors

### 5.3.1 FieldServer Related Map Descriptor Parameters

Column Title	Function	Legal Values
Map_Descriptor_Name	Name of this Map Descriptor	Up to 32 alphanumeric characters
Data_Array_Name	Name of Data Array where data is to be stored in the FieldServer	One of the Data Array names specified in Section 4.
Data_Array_Offset	Starting location in Data Array	0 to (Data_Array_Length -1) as defined in Section 4.
Function	Function of Client Map Descriptor	Arco, Awt, Rdbc, Passive_Client, Arcs. Refer to Appendix A.1 for more information.

5.3.2 Driver Related Map Descriptor Parameters

Column Title	Function	Legal Values
Node_Name	Name of Node to fetch data from	One of the node names specified in "Client Node Descriptor" above
Grafik_Command	Specifies the command that will be sent to the eLumen.	<u>Area Machine:</u> Run_Script_AB Area_Sts_Offscene Sel_Scene_In_Area Run_Script_Multi Area_Status Scene_In_Area_Status Sys_Var_Val_Bin Sys_Var_Val <u>Zone Machine:</u> Run_Script_Ab Zone_Intensity Fade_Zone Run_Script_Multi Zone_Intensity Sys_Var_Val_Bin Sys_Var_Val
DA_Lut_List	Name of Data Array that contains a list of parameters needed to execute the command.	A Data Array name.
DA_Lut_List_Offset	The offset into the DA_Lut_List Data Array from where the list data is to be used.	0 to the maximum offset into the DA_Lut_List Data Array.
DA_Lut_Parms	Name of Data Array that contains parameters needed to execute the command.	A Data Array name.
DA_Lut_Parms_Offset	The offset into the DA_Lut_Parms Data Array where the driver will retrieve the parameters.	0 to the maximum offset into the DA_Lut_Parms Data Array.
Area	GRAFIK system area number	0 – 511
Sys_var	GRAFIK system variable number	0 – 65535
Zone	GRAFIK system zone number	0 – 511
Length	Length of Map Descriptor. The length is an indication of the number of data elements this Map Descriptor is responsible for updating. It is used in the overall points calculation of the FieldServer.	See example Map Descriptors for individual lengths per Map Descriptor.
Multi_Scripts_Length	The length of the Data Array specified under DA_Lut_List when used with Grafik command: run_script_multi	1 – 10,000

5.3.3 Timing Parameters

Column Title	Function	Legal Values
Scan_Interval	Rate at which data is polled	≥0.001s

### 5.3.4 Map Descriptor Example 1 - Binary Output (Zone and Area Machine)

A write to the Binary Output Data Array which is shared by a BACNet IP Map Descriptor will execute one of two scripts on the eLumen panel. The script numbers corresponding to binary inactive (0) and active (1) are specified in the Data Array specified by DA\_Lut\_List from offset specified by DA\_Lut\_List\_Offset. Script numbers are in decimal and range from 0 to 65535.

#### BACnet IP Map Descriptor

```
// Client Side Map Descriptors

Map_Descriptors
Map_Descriptor_Name , Data_Array_Name , Data_Array_Offset , Function , Node_Name , Data_Type , Object_ID , Length , Relinquish_Default
SMD00_BO , Binary_Output , 0 , Passive , Virtual_BCU_11 , BO , 1 , 512 , 0
```

#### Lutron Machine Map Descriptor

```
// Client Side Map Descriptors

Map_Descriptors
Map_Descriptor_Name , Data_Array_Name , Data_Array_Offset , Function , Node_Name , Grafik_Command , DA_Lut_List , DA_Lut_List_Offset , Length
Run_Script_0 , Binary_Output , 0 , Awt , LUT_GRF6_0 , run_script_AB , Script_list_BO , 0 , 512
```

The Data Array specified under “DA\_Lut\_List” must be preloaded with script numbers as shown below:

- ScriptA in even locations, ScriptB in uneven locations, values in Preload\_Data\_Value
- ScriptA will be run when writing zero into the Object ID
- ScriptB will be run when writing non-zero into the object ID

```

Preloads
Data_Array_Name , Preload_Data_Format , Preload_Data_Value , Location

// Binary Output Object ID 1
Script_list_BO , Uint16 , 1 , 0
Script_list_BO , Uint16 , 2 , 1

// Binary Output Object ID 2
Script_list_BO , Uint16 , 3 , 2
Script_list_BO , Uint16 , 4 , 3
    
```

5.3.5 Map Descriptor Example 2 - Binary Input (Zone Machine)

A read from the Binary Input Data Array which is shared by a BACNet IP Map Descriptor will return the relay state for the given zone. The Lutron Machine Map Descriptor regularly polls the eLumen panel to retrieve the value of zone intensity. The value of each BACnet object presenting Binary Output is inactive if the intensity is zero and active if the intensity is non-zero. Zone numbers range from 0 to 511

BACNet IP Map Descriptor

```

// Client Side Map Descriptors

Map_Descriptors
Map_Descriptor_Name , Data_Array_Name , Data_Array_Offset , Function , Node_Name , Data_Type , Object_ID , Length , Relinquish_Default
SMD00_BI , Binary_Input , 0 , Passive , Virtual_BCU_11 , BI , 1 , 512 , 0
    
```

Lutron Machine Map Descriptor

```

// Client Side Map Descriptors

Map_Descriptors
Map_Descriptor_Name , Data_Array_Name , Data_Array_Offset , Function , Node_Name , Grafik_Command , Zone , Length
Zone_int_0 , Binary_Input , 0 , Arco , LUT_GRF6_0 , Zone_Intensity , 0 , 512
    
```

5.3.6 Map Descriptor Example 3 - Binary Input (Area Machine)

A read from the Binary Input Data Array which is shared by a BACNet IP Map Descriptor will return the scene-on state for the given area. The Lutron Machine Map Descriptor regularly polls the eLumen panel to retrieve the scene-on state for the given area. The value returned by the BACNet object is inactive (0) if the off scene is selected and active (1) if any other scene is selected. The off scene numbers range from 0 to 65535 and are preloaded in the Data Array specified under "DA\_Lut\_List".

**BACNet IP Map Descriptor**

```
// Client Side Map Descriptors

Map_Descriptors
Map_Descriptor_Name , Data_Array_Name , Data_Array_Offset , Function , Node_Name , Data_Type , Object_ID , Length , Relinquish_Default
SMD00_BI , Binary_Input , 0 , Passive , Virtual_BCU_11 , BI , 1 , 512 , 0
```

Lutron Machine Map Descriptor

```
// Client Side Map Descriptors

Map_Descriptors
Map_Descriptor_Name , Data_Array_Name , Data_Array_Offset , Function , Node_Name , Grafik_Command , Area , DA_Lut_List , DA_Lut_List_Offset , Length
Area_sts_0 , Binary_Input , 0 , Arco , LUT_GRF6_0 , Area_Sts_Offscene , 0 , Off_Scene , 0 , 512
```

```
Preloads
Data_Array_Name , Preload_Data_Format , Preload_Data_Value , Location

// Binary Input Object ID 1
off_scene , Uint16 , 0 , 0

// Binary Input Object ID 2
off_scene , Uint16 , 1 , 1
```

Insert the off-scene number into the Preload\_Data\_Value field

### 5.3.7 Map Descriptor Example 4 - Analog Output 1 (Area Machine)

A write to the Analog Output Data Array which is shared by a BACNet IP Map Descriptor will command an area to a preset scene on the Lutron eLumen panel. Scenes range from 0 to 65535 and area numbers range from 0 to 511

#### BACNet IP Map Descriptor

```
// Client Side Map Descriptors

Map_Descriptors
Map_Descriptor_Name , Data_Array_Name , Data_Array_Offset , Function , Node_Name , Data_Type , Object_ID , Length , Relinquish_Default
SMD000_AO , Analog_Output , 0 , Passive , Virtual_BCU_11 , AO , 1 , 512 , 0
```

#### Lutron Machine Map Descriptor

```
// Client Side Map Descriptors

Map_Descriptors
Map_Descriptor_Name , Data_Array_Name , Data_Array_Offset , Function , Node_Name , Grafik_Command , Area , Length
Sel_scene_0 , Analog_Output , 0 , Awt , LUT_GRF6_0 , Sel_Scene_In_Area , 0 , 512
```

The area field must be used to indicate the start area number that will be associated with the first element of the Data Array specified under Data\_Array\_Name. Area numbers increase with the Length field in association with increasing offset into the Data Array.

### 5.3.8 Map Descriptor Example 5 - Analog Output 1 (Zone Machine)

A write to the Analog Output Data Array which is shared by a BACNet IP Map Descriptor will command a zone on the Lutron eLumen panel to the written intensity. Intensities are written as a percentage value (0 to 100%).

#### BACNet IP Map Descriptor

```
// Client Side Map Descriptors

Map_Descriptors
Map_Descriptor_Name , Data_Array_Name , Data_Array_Offset , Function , Node_Name , Data_Type , Object_ID , Length , Relinquish_Default
SMD000_AO , Analog_Output , 0 , Passive , Virtual_BCU_11 , AO , 1 , 512 , 0
```

#### Lutron Machine Map Descriptor

```
// Client Side Map Descriptors

Map_Descriptors
Map_Descriptor_Name , Data_Array_Name , Data_Array_Offset , Function , Node_Name , Grafik_Command , Zone , DA_Lut_Parms , DA_Lut_Parms_Offset , Length
Fade_to_lvl_0 , Analog_Output , 0 , Awt , LUT_GRF6_0 , Fade_Zone , 0 , Zone_Pars_AO1 , 0 , 512
```

The zone field must be used to indicate the start zone number that will be associated with the first element of the Data Array specified under Data\_Array\_Name . Zone numbers increase with the Length field in association with increasing offset into the Data Array.

Fade and Delay times per zone must be preloaded into the Data Array specified under “DA\_Lut\_Parms”:

#### Analog Output1 Settings Setup

- All values are in decimal ( 0 - 65535 )
- Fade time in even locations, Delay time in uneven locations
- Fill in time values under Preload\_Data\_Value

```

Preloads
Data_Array_Name , Preload_Data_Format , Preload_Data_Value , Location

// Analog Output1 Object ID 1
Zone_pars_AO1 , Uint16 , 0 , 0
Zone_pars_AO1 , Uint16 , 1 , 1

// Analog Output1 Object ID 2
Zone_pars_AO1 , Uint16 , 2 , 2
Zone_pars_AO1 , Uint16 , 3 , 3

```

### 5.3.9 Map Descriptor Example 6 - Analog Output 2 (Zone and Area Machine)

A write to the Analog Output Data Array which is shared by a BACNet IP Map Descriptor will execute one of multiple scripts on the Lutron eLumen panel. The value written into the Analog Output Data Array is used as an offset into the Data Array defined under "DA\_Lut\_List" to retrieve a script number. Script numbers range from 0 to 65535.

#### BACNet IP Map Descriptor

```

// Client Side Map Descriptors

Map_Descriptors
Map_Descriptor_Name , Data_Array_Name , Data_Array_Offset , Function , Node_Name , Data_Type , Object_ID , Length , Relinquish_Default
SMD512_AO , Analog_Output , 512 , Passive , Virtual_BCU_11 , AO , 513 , 512 , 0

```

#### Lutron Machine Map Descriptor

```

// Client Side Map Descriptors

Map_Descriptors
Map_Descriptor_Name , Data_Array_Name , Data_Array_Offset , Function , Node_Name , Grafik_Command , DA_Lut_List , DA_Lut_List_Offset , Length , Multi_Scripts_Length
Run_script_512 , Analog_Output , 512 , Awt , LUT_GRF6_0 , Run_Script_Multi , Scr_Lst_AO2_512 , 0 , 1 , 10

```

The Multi\_Scripts\_Length field is used to indicate the maximum size of the Data Array specified under Data\_Array\_Name. One Map Descriptor per object must be defined with a Multi\_Scripts\_Length value of 1 or greater.

The script numbers per BACNet object element need to be preloaded into the Data Arrays defined under "DA\_Lut\_List".

Analog Output2 Settings Setup

- All values are in decimal ( 0 - 65535 )
- Specify up to 10 scripts for each Object ID by editing Preload\_Data\_Value

Preloads	Data_Array_Name	, Preload_Data_Format	, Preload_Data_Value	, Location
// Analog Output2 Object ID 513				
	Scr_Ist_AO2_512	, Uint16	, 100	, 0
	Scr_Ist_AO2_512	, Uint16	, 200	, 1
	Scr_Ist_AO2_512	, Uint16	, 300	, 2
	Scr_Ist_AO2_512	, Uint16	, 400	, 3
	Scr_Ist_AO2_512	, Uint16	, 500	, 4
	Scr_Ist_AO2_512	, Uint16	, 600	, 5
	Scr_Ist_AO2_512	, Uint16	, 700	, 6
	Scr_Ist_AO2_512	, Uint16	, 800	, 7
	Scr_Ist_AO2_512	, Uint16	, 900	, 8
	Scr_Ist_AO2_512	, Uint16	, 65000	, 9
// Analog Output2 Object ID 514				
	Scr_Ist_AO2_513	, Uint16	, 101	, 0
	Scr_Ist_AO2_513	, Uint16	, 201	, 1
	Scr_Ist_AO2_513	, Uint16	, 301	, 2
	Scr_Ist_AO2_513	, Uint16	, 401	, 3
	Scr_Ist_AO2_513	, Uint16	, 501	, 4
	Scr_Ist_AO2_513	, Uint16	, 601	, 5
	Scr_Ist_AO2_513	, Uint16	, 701	, 6
	Scr_Ist_AO2_513	, Uint16	, 801	, 7
	Scr_Ist_AO2_513	, Uint16	, 901	, 8
	Scr_Ist_AO2_513	, Uint16	, 65001	, 9

### 5.3.10 Map Descriptor Example 7 - Analog Input (Area Machine)

A read from the Analog Input Data Array which is shared by a BACNet IP Map Descriptor will return the last scene selected in a given area on the Lutron eLumen panel. The Lutron Machine Map Descriptor regularly polls the Lutron eLumen panel to retrieve the scene numbers.

#### BACNet IP Map Descriptor

```
// Client Side Map Descriptors

Map_Descriptors
Map_Descriptors_Name ,Data_Array_Name ,Data_Array_Offset ,Function ,Node_Name ,Data_Type ,Object_ID ,Length ,Relinquish_Default ,Data_Array_Low_Scale ,Data_Array_High_Scale ,Node_Low_Scale ,Node_High_Scale
SMD00_AI ,Analog_Input ,0 ,Server ,Virtual_BCU_11 ,AI ,1 ,1 ,0 ,0 ,100 ,0 ,100
```

The last scene value may be scaled:

#### Analog Input Settings Setup

- All values are in decimal ( 0 - 65535 )
- Insert a first available scene number under the Data\_Array\_High\_Scale field for each Object ID or use the scale fields as desired to scale scene numbers.
- Object IDs are contiguous

#### Lutron Machine Map Descriptor

```
// Client Side Map Descriptors

Map_Descriptors
Map_Descriptor_Name ,Data_Array_Name ,Data_Array_Offset ,Function ,Node_Name ,Grafik_Command ,Area ,Length
Last_scene_0 ,Analog_Input ,0 ,Arco ,LUT_GRF6_0 ,Area_Status ,0 ,512
```

### 5.3.11 Map Descriptor Example 7 - Analog Input (Area Machine)

A read from the Analog Input Data Array which is shared by a BACNet IP Map Descriptor will return the last scene selected in a given area on the Lutron eLumen panel. The Lutron Machine Map Descriptor regularly polls the Lutron eLumen panel to retrieve the scene numbers.

#### BACNet IP Map Descriptor

```
// Client Side Map Descriptors

Map_Descriptors
Map_Descriptors_Name ,Data_Array_Name ,Data_Array_Offset ,Function ,Node_Name ,Data_Type ,Object_ID ,Length ,Relinquish_Default ,Data_Array_Low_Scale ,Data_Array_High_Scale ,Node_Low_Scale ,Node_High_Scale
SMD00_AI ,Analog_Input ,0 ,Server ,Virtual_BCU_11 ,AI ,1 ,1 ,0 ,0 ,100 ,0 ,100
```

The last scene value may be scaled:

#### Analog Input Settings Setup

- All values are in decimal ( 0 - 65535 )
- Insert a first available scene number under the Data\_Array\_High\_Scale field for each Object ID or use the scale fields as desired to scale scene numbers.
- Object IDs are contiguous

#### Lutron Machine Map Descriptor

```
// Client Side Map Descriptors

Map_Descriptors
Map_Descriptor_Name ,Data_Array_Name ,Data_Array_Offset ,Function ,Node_Name ,Grafik_Command ,Area ,Length
Last_scene_0 ,Analog_Input ,0 ,Arco ,LUT_GRF6_0 ,Scene_In_Area_Status ,0 ,512
```

### 5.3.12 Map Descriptor Example 8 - Analog Input (Zone Machine)

A read from the Analog Input Data Array which is shared by a BACNet IP Map Descriptor will return the intensity to which a given zone is set on the Lutron eLumen panel. The Lutron Machine Map Descriptor regularly polls the Lutron eLumen panel to retrieve the zone intensities. The intensity value returned is scaled to a percentage value (0 to 100%). Zone numbers range from 0 to 511.

#### BACNet IP Map Descriptor

```
// Client Side Map Descriptors

Map_Descriptors
Map_Descriptor_Name , Data_Array_Name , Data_Array_Offset , Function , Node_Name , Data_Type , Object_ID , Length , Relinquish_Default
SMD00_AI , Analog_Input , 0 , Passive , Virtual_BCU_11 , AI , 1 , 512 , 0
```

#### Lutron Machine Map Descriptor

```
// Client Side Map Descriptors

Map_Descriptors
Map_Descriptor_Name , Data_Array_Name , Data_Array_Offset , Function , Node_Name , Grafik_Command , Zone , Length
Zone_inta_0 , Analog_Input , 0 , Arco , LUT_GRF6_0 , Zone_Intensity , 0 , 512
```

### 5.3.13 Map Descriptor Example 9 - Multistate Output (Zone and Area Machine)

A write to the Multistate Output Data Array which is shared by a BACNet IP Map Descriptor will execute one of multiple scripts. The multiple scripts are specified in the Data Array defined under "DA\_Lut\_List". The value written into the Multistate Output Data Array is used as the offset into the Data Array defined under "DA\_Lut\_List" to retrieve a script number from the Data Array. Script numbers range from 0 to 65535.

#### BACNet IP Map Descriptor

```
// Client Side Map Descriptors

Map_Descriptors
Map_Descriptor_Name , Data_Array_Name , Data_Array_Offset , Function , Node_Name , Data_Type , Object_ID , Length , Relinquish_Default
SMD00_MO , MultiSt_Output , 0 , Passive , Virtual_BCU_11 , MO , 1 , 512 , 0
```

#### Lutron Machine Map Descriptor

```
// Client Side Map Descriptors

Map_Descriptors
Map_Descriptor_Name , Data_Array_Name , Data_Array_Offset , Function , Node_Name , Grafik_Command , DA_Lut_List , DA_Lut_List_Offset , Length , Multi_Scripts_Length
Run_scriptms_0 , MultiSt_Output , 0 , Awt , LUT_GRF6_0 , Run_Script_Multi , Scr_Lst_MSO_0 , 0 , 1 , 10
```

The Multi\_Scripts\_Length field is used to indicate the maximum size of the Data Array specified under Data\_Array\_Name. One Map Descriptor per object must be defined with a Multi\_Scripts\_Length value of one or greater.

The scripts per object element must be preloaded into the Data Array defined under "DA\_Lut\_List":

Multistate Output Scripts Setup

- All values are in decimal ( 0 - 65535 )
- Specify up to 10 scripts for each Object ID by editing Preload\_Data\_Value

Preloads			
Data_Array_Name	, Preload_Data_Format	Preload_Data_Value	Location
// Multistate Output Object ID 1			
Scr_lst_MSO_0	, Uint16	, 110	, 0
Scr_lst_MSO_0	Uint16	, 210	, 1
Scr_lst_MSO_0	Uint16	, 310	, 2
Scr_lst_MSO_0	Uint16	, 410	, 3
Scr_lst_MSO_0	Uint16	, 510	, 4
Scr_lst_MSO_0	Uint16	, 610	, 5
Scr_lst_MSO_0	Uint16	, 710	, 6
Scr_lst_MSO_0	Uint16	, 810	, 7
Scr_lst_MSO_0	Uint16	, 910	, 8
Scr_lst_MSO_0	Uint16	, 65010	, 9
// Multistate Output Object ID 2			
Scr_lst_MSO_1	Uint16	, 120	, 0
Scr_lst_MSO_1	Uint16	, 220	, 1
Scr_lst_MSO_1	Uint16	, 320	, 2
Scr_lst_MSO_1	Uint16	, 420	, 3
Scr_lst_MSO_1	Uint16	, 520	, 4
Scr_lst_MSO_1	Uint16	, 620	, 5
Scr_lst_MSO_1	Uint16	, 720	, 6
Scr_lst_MSO_1	Uint16	, 820	, 7
Scr_lst_MSO_1	Uint16	, 920	, 8
Scr_lst_MSO_1	Uint16	, 65020	, 9

### 5.3.14 Map Descriptor Example 10 - Binary Value (Zone and Area Machine)

A read from the Binary Value Data Array which is shared by a BACNet IP Map Descriptor will return the current value of a system variable in the Lutron eLumen panel. The value returned is inactive (0) if the system variable is zero and active (1) if non-zero. The Lutron Machine Map Descriptor regularly polls the Lutron panel to retrieve the system variable values. A write to the Binary Value Data Array will set the system variable to 255 on active (1) write or to zero on inactive (0) write.

#### BACNet IP Map Descriptor

```
// Client Side Map Descriptors

Map_Descriptors
Map_Descriptor_Name , Data_Array_Name , Data_Array_Offset , Function , Node_Name , Data_Type , Object_ID , Length , Relinquish_Default
SMD00_BV , Binary_Value , 0 , Passive , Virtual_BCU_11 , BV , 1 , 512 , 0
```

#### Lutron Machine Map Descriptor

```
// Client Side Map Descriptors

Map_Descriptors
Map_Descriptor_Name , Data_Array_Name , Data_Array_Offset , Function , Node_Name , Grafik_Command , Sys_Var , Length
Zone_var_0 , Binary_Value , 0 , Arco , LUT_GRF6_0 , Sys_Var_Val_Bin , 0 , 512
```

### 5.3.15 Map Descriptor Example 11 - Analog Value (Zone and Area Machine)

A read from the Analog Value Data Array which is shared by a BACNet IP Map Descriptor will return the current value of a system variable in the Lutron eLumen panel. The variable values range from 0 to 255. The Lutron Machine Map Descriptors are regularly updated with system variable values from the active Binary Value Map Descriptors. A write to the Analog Value Data Array will set the system variable to the written value.

#### BACNet IP Map Descriptor

```
// Client Side Map Descriptors

Map_Descriptors
Map_Descriptor_Name , Data_Array_Name , Data_Array_Offset , Function , Node_Name , Data_Type , Object_ID , Length , Relinquish_Default
SMD00_AV , Analog_Value , 0 , Passive , Virtual_BCU_11 , AV , 1 , 512 , 0
```

#### Lutron Machine Map Descriptor

```
// Client Side Map Descriptors

Map_Descriptors
Map_Descriptor_Name , Data_Array_Name , Data_Array_Offset , Function , Node_Name , Grafik_Command , Sys_Var , Length
Zone_Vara_0 , Analog_Value , 0 , Passive_Client , LUT_GRF6_0 , Sys_Var_Val , 0 , 512
```

The Passive\_Client function is used to prevent double-polling the Lutron eLumen panel for system variables. The Analog Value Map Descriptors should be set up identical to the Binary Value Map Descriptors in terms of the Sys\_Var and Length fields to ensure system variable values will be stored correctly.

## Appendix A. Useful Features

## Appendix A.1. Map Descriptor Functions

Function	Description
Rdbc	This is an active Map Descriptor which polls the device once every scan interval.
Arco	The Arco function is the same as Rdbc except that the length of the Map Descriptor is taken as the number of zones to poll. The start zone number is specified under the Zone Map Descriptor field. More than one Arco Map Descriptor may be used to poll two series of zone numbers, eg. from 5-10 and from 300-340. Arco Map Descriptors with Length 1 perform the same function as Rdbc Map Descriptors with the same length.
Awt	This function is used to effect a single data write per trigger. The write only occurs when the Data Array is updated.
Passive_Client	The Server device writes to the FieldServer's Data Arrays, and the Client device reads the data from the same Data Arrays.
Arcs	This function will perform the same operation as an Rdbc (Arc) function, but will sequence through the range of addresses starting at "Address" and wrapping at "Address + Length". A length of 1 will be used for every one of the Addresses that gets polled.