



A Sierra Monitor Company

**Driver Manual**  
**(Supplement to the FieldServer Instruction Manual)**

**FS-8700-90 (Notifier NFS-640 NFS-320 NFS2-640)**

**APPLICABILITY & EFFECTIVITY**

**Effective for all systems manufactured after November 2009**

Driver Version: 1.04  
Document Revision: 1

**TABLE OF CONTENTS**

<b>1</b>	<b>Notifier Onyx™ NFS-640, NFS2-640, NFS-320 Description</b> .....	<b>3</b>
<b>2</b>	<b>Driver Scope of Supply</b> .....	<b>3</b>
2.1	Supplied by FieldServer Technologies for this driver .....	3
2.2	Provided by the Supplier of 3rd Party Equipment.....	3
2.2.1	<i>Hardware</i> .....	3
2.2.2	<i>Required 3rd Party Configuration</i> .....	3
<b>3</b>	<b>Hardware Connections</b> .....	<b>4</b>
3.1	Notifier Onyx NFS-640 Panel .....	4
3.2	Notifier Onyx NFS2-640 Panel .....	5
<b>4</b>	<b>Data Array Parameters</b> .....	<b>6</b>
<b>5</b>	<b>Configuring the FieldServer as a Notifier Onyx Client</b> .....	<b>7</b>
5.1	Client Side Connection Parameters .....	7
5.2	Client Side Node Parameters .....	7
5.3	Client Side Map Descriptor Parameters .....	8
5.3.1	<i>FieldServer Related Map Descriptor Parameters</i> .....	8
5.3.2	<i>Driver Related Map Descriptor Parameters</i> .....	8
5.3.3	<i>Map Descriptor Example 1 – Storing Data</i> .....	9
<b>Appendix A</b>	<b>Useful Features</b> .....	<b>10</b>
Appendix A.1.	Enabling the NFS-640/NFS2-640 CRT Port .....	10
Appendix A.2.	Connection to CRT Port .....	10
Appendix A.3.	NFS-Polling for Panel Status via CRT Port .....	11
Appendix A.3.1.	<i>FieldServer Related Map Descriptor Parameters</i> .....	11
Appendix A.3.2.	<i>Driver Related Map Descriptor Parameters</i> .....	11
Appendix A.3.3.	<i>Timing Parameters</i> .....	11
Appendix A.3.4.	<i>Map Descriptor Example 2 – Synch the Panel to the FieldServer</i> .....	12
Appendix A.3.5.	<i>Nfs_Clear_On_Sys_Reset - Settings Table</i> .....	12
<b>Appendix B</b>	<b>Troubleshooting</b> .....	<b>13</b>
Appendix B.1.	Driver Limitations & Exclusions .....	13
<b>Appendix C</b>	<b>Reference</b> .....	<b>14</b>
Appendix C.1.	Message to Data Array Mapping .....	14
Appendix C.1.1.	<i>Panel Status Data Array Mapping</i> .....	14
Appendix C.1.2.	<i>Calculating Array Offset for a Given Detector/Module/Zone etc.</i> .....	15
Appendix C.2.	Notifier NFS-640 Message Types Recognized .....	16
Appendix C.3.	System Trouble Messages .....	19
Appendix C.4.	Driver Error Messages .....	21
Appendix C.5.	FieldServer Statistics.....	22

## 1 NOTIFIER ONYX™<sup>1</sup>NFS-640, NFS2-640, NFS-320 DESCRIPTION

The NFS-640 Serial driver allows the FieldServer to record data from Notifier Onyx Series NFS-640, NFS2-640 and NFS-320 Fire Panels over RS-232. The FieldServer primarily acts as a Passive Client receiving unsolicited messages and updating the status of a Notifier Fire Alarm Panel.

The main purpose of this driver is to record the status of Fire Alarm System detectors and modules in a bit oriented Data Array. It is limited by the information that the Notifier Panel broadcasts in the form of text messages through its RS-232 communication port. The accuracy and timeliness of the data is therefore limited by the frequency of update messages that the Notifier Fire Panel issues.

The types of Notifier messages supported by this driver are summarized in Appendix C.1. A detailed table showing each type of panel message the FieldServer recognizes and the effect that it has on the status of points in the data array is presented in Appendix C.2. The device status to the data array mapping is also provided in Appendix C.2.

It is possible to connect through the CRT Port., however the use of this port restricts the use of Notifier Networking, thus a fire panel connected to a Noti-Fire-Net will not be supported. If the CRT port is used, the FieldServer can actively request the status of all points, devices and zones on a periodic basis. This status request is configurable from 5minutes with no upper bounds. Note that communication through this port does not equate to Port Supervision. Refer to Appendix A.1

The panel *must* output messages in English. For Notifier 640 Onyx firmware with Spanish firmware (as sold in Mexico and other Central and South American markets) please refer to the fact sheet 'FST\_DFS\_Notifier\_NFS-640 (Onyx)(Spanish)'

FieldServer mode	Nodes	Comments
Client		This driver is connection oriented - only one Notifier Panel may be connected to any single RS-232 FieldServer port.

## 2 DRIVER SCOPE OF SUPPLY

### 2.1 Supplied by FieldServer Technologies for this driver

FieldServer Technologies PART #	Description
FS-8917-16	RJ45 Pigtail Cable

### 2.2 Provided by the Supplier of 3rd Party Equipment

#### 2.2.1 Hardware

PART #	Description
	Notifier Onyx NFS-640, NFS2-640 or NFS-320 Fire Panel

#### 2.2.2 Required 3rd Party Configuration

If connection through the CRT port is required then the port needs to be enabled. Refer to Appendix A.1

<sup>1</sup> Onyx is a trademark of Notifier.

### 3 HARDWARE CONNECTIONS

#### 3.1 Notifier Onyx NFS-640 Panel

The FieldServer is connected to the Notifier Onyx NFS-640 Panel as shown below. Configure the Notifier Onyx NFS-640 Panel according to manufacturer’s instructions. Note that the recommended connection through the printer port is depicted in the diagram. If preferred, connection can be made through the CRT port. Refer to Appendix A.2 for more information.

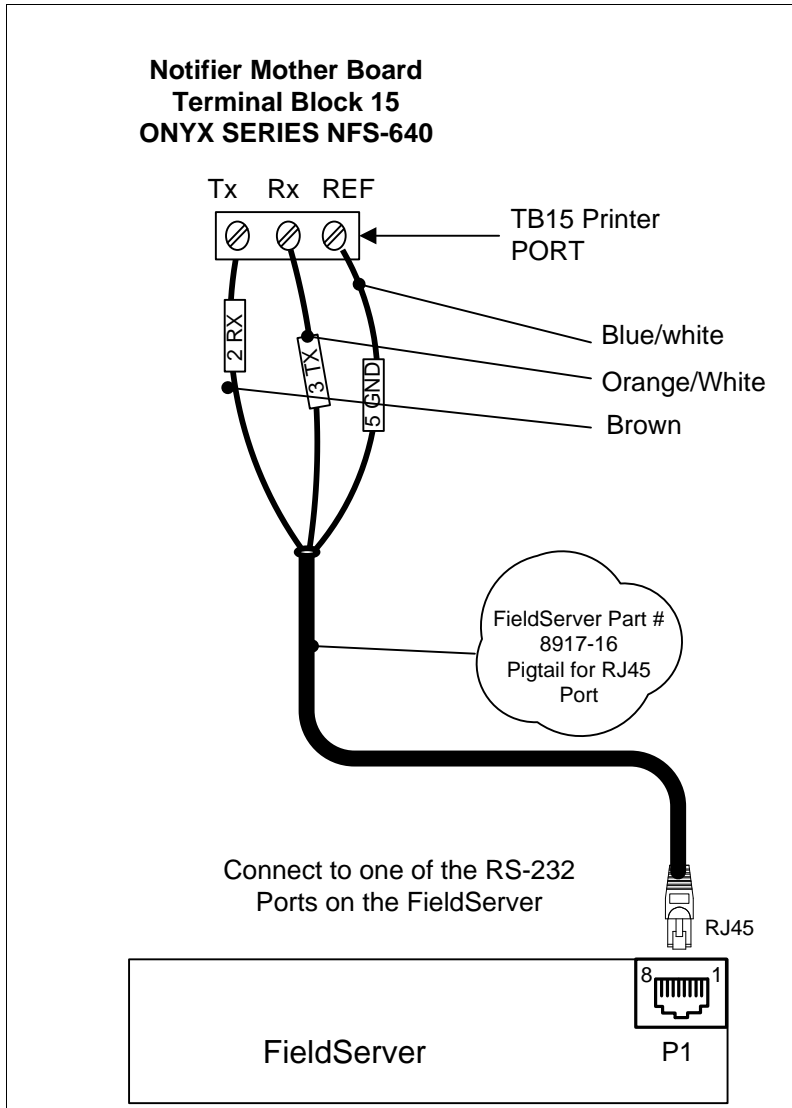

3.2 Notifier Onyx NFS2-640 Panel

The FieldServer is connected to the Notifier Onyx NFS2-640 Panel as shown below. Configure the Notifier Onyx NFS2-640 Panel according to manufacturer’s instructions. Note that the recommended connection through the printer port is depicted in the diagram. If preferred, connection can be made through the CRT port. Refer to Appendix A.2 for more information.

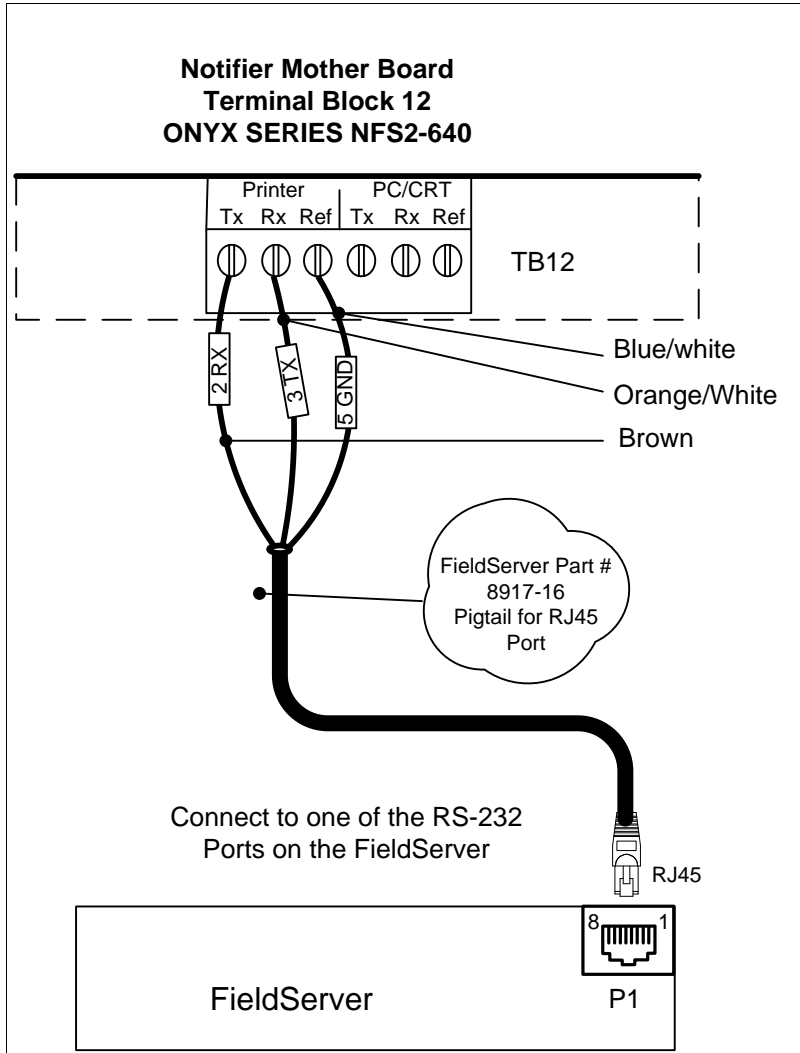

## 4 DATA ARRAY PARAMETERS

Data Arrays are “protocol neutral” data buffers for storage of data to be passed between protocols. It is necessary to declare the data format of each of the Data Arrays to facilitate correct storage of the relevant data.

Section Title		
Data_Arrays		
Column Title	Function	Legal Values
Data_Array_Name	Provide name for Data Array	Up to 15 alphanumeric characters
Data_Array_Format	Provide data format. Each Data Array can only take on one format.	Bit
Data_Array_Length	Number of Data Objects. Must be larger than the data storage area required by the Map Descriptors for the data being placed in this array.	4800

### Example

```
// Data Arrays
Data_Arrays
Data_Array_Name , Data_Array_Format , Data_Array_Length
DA_AI_01 , Bit , 4800
```

## 5 CONFIGURING THE FIELDSEVER AS A NOTIFIER ONYX CLIENT

For a detailed discussion on FieldServer configuration, please refer to the FieldServer instruction manual. The information that follows describes how to expand upon the factory defaults provided in the configuration files included with the FieldServer (See “.csv” sample files provided with the FieldServer).

This section documents and describes the parameters necessary for configuring the FieldServer to communicate with a Notifier NFS-640, NFS-320 or NFS2-640 Server.

It is possible to connect the Notifier panel to any RS-232 port on the FieldServer. These ports need to be configured for Protocol="nfs" in the configuration files.

### 5.1 Client Side Connection Parameters

Section Title		
Connections		
Column Title	Function	Legal Values
Port	Specify which port the device is connected to the FieldServer	P1-P8 <sup>2</sup>
Protocol	Specify protocol used	Nfs, onyx, nfs-320, nfs2-640
Baud*	Specify baud rate	<b>9600</b> (Vendor limitation)
Parity*	Specify parity	<b>None</b> (Vendor limitation)
Data_Bits*	Specify data bits	<b>8</b> (Vendor limitation)
Stop_Bits*	Specify stop bits	<b>1</b> (Vendor limitation)

#### Example

//	Client Side Connections					
Port	,	Protocol	,	Baud	,	Parity
P1	,	Nfs	,	9600	,	None

### 5.2 Client Side Node Parameters

Section Title		
Nodes		
Column Title	Function	Legal Values
Node_Name	Provide name for Node	Up to 32 alphanumeric characters
Node_ID	Unique station address of physical Server Node	1-255
Protocol	Specify Protocol used	Nfs, onyx, nfs-320, nfs2-640
Connection	Specify through which port the device is connected to the FieldServer	P1-P8 <sup>2</sup>

<sup>2</sup> Not all ports shown are necessarily supported by the hardware. Consult the appropriate Instruction manual for details of the ports available on specific hardware.

**Example**

```
// Client Side Nodes

Nodes
Node_Name , Node_ID , Protocol , Connection
PLC 1 , 1 , Nfs , P8
```

**5.3 Client Side Map Descriptor Parameters****5.3.1 FieldServer Related Map Descriptor Parameters**

Column Title	Function	Legal Values
Map_Descriptor_Name	Name of this Map Descriptor	Up to 32 alphanumeric characters
Data_Array_Name	Name of Data Array where data is to be stored in the FieldServer	One of the Data Array names specified in Section 4
Data_Array_Offset	Starting location in Data Array	0
Function	Function of Client Map Descriptor	Passive

**5.3.2 Driver Related Map Descriptor Parameters**

Column Title	Function	Legal Values
Node_Name	Name of Node to store data to	One of the Node names specified in Section 5.2
Length*	Length of Map Descriptor.	Large enough to store the required data, <b>1</b>
Address	Selects Client Map Descriptor functions	7777

5.3.3 Map Descriptor Example 1 – Storing Data.

This is a typical example of a Passive Client Map Descriptor, which only reads incoming messages. All messages will be recorded in the Data Array designated to this port. The Data Array must be of the size designated in Data Arrays above. The offset and length are not used by the driver, but must be set to reasonable values to pass driver validation.

Map_Descriptor_Name	Data_Array_Name	Data_Array_Offset	Function	Node_Name	Address	Length
MD1_Panel1_Data	DA_Panel1	0	Passive	Panel1	7777	4800

The Data Array name where status bits for all messages received on a port will be stored.

The offset is ignored - the driver always uses an offset of zero.

Designates that this Map Descriptor waits for incoming messages and does not poll

There can only be one Node per port. This field indirectly links the FieldServer port to a data storage array. Refer to Section 5.2.

An address of 7777 indicates that this is a passive Map Descriptor used to store data only

## Appendix A. Useful Features

### Appendix A.1. Enabling the NFS-640/NFS2-640 CRT Port

Before communication can be achieved through the CRT port, this port needs to be enabled. To enable this port the following steps must be followed:

1. Program the NFS-640/NFS2-640 to communicate through the CRT Port
  - Press "Enter" on the keypad
  - Press "I"
  - Type "CRT96"
  - Press "Enter"
  - Press "Esc" Twice
2. Disable communication through the CRT Port
  - Press "Enter" on the keypad
  - Press "I"
  - Type "NOCRT"
  - Press "Enter"
  - Press "Esc" Twice

### Appendix A.2. Connection to CRT Port

The FieldServer is connected to the Notifier NFS2-640 CRT port as shown below.

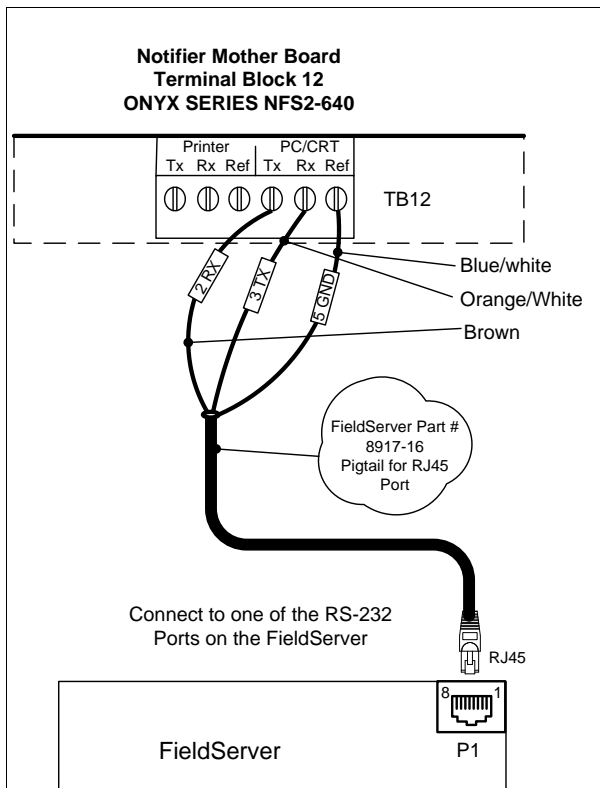

Appendix A.3. NFS-Polling for Panel Status via CRT Port

When connected to the CRT port of the NFS-640 or NFS2-640 panel, the client can poll the Notifier panel for status, and interpret and record the data from a critical subset of all the messages that the panel generates. The device status is mapped to a bit array in the FieldServer as described below.

Appendix A.3.1. FieldServer Related Map Descriptor Parameters

Column Title	Function	Legal Values
Map_Descriptor_Name	Name of this Map Descriptor	Up to 32 alphanumeric characters
Data_Array_Name	Name of Data Array where data is to be stored in the FieldServer	One of the Data Array names from "Data Array" section above
Data_Array_Offset	Starting location in Data Array	0
Function	Function of Client Map Descriptor	Passive, Rdbc

Appendix A.3.2. Driver Related Map Descriptor Parameters

Column Title	Function	Legal Values
Node_Name	Name of Node to store data to	One of the Node names specified in "Client Node Descriptor" above
Length	Length of Map Descriptor. The length of the active Map Descriptor may be set to 1 as the response data is always stored using the passive Map Descriptor. The length of the passive Map Descriptor must be set to 4800 or greater.	at least 1 (default)
Address	Selects Client Map Descriptor functions	7777 for passive Map Descriptor; 8888 for polling Map Descriptor
Nfs_Clear_On_Sys_Reset*	Selects memory area to be cleared on "SYSTEM RESET"	0 or sum of any combination of 1,2,4,8,16,32,64,128 and 512 Or 32768.  Refer to Appendix A.3.5 for more information.

Appendix A.3.3. Timing Parameters

Column Title	Function	Legal Values
Scan_Interval*	Minimum time interval between scans	0.001s-65535s, <b>600s</b>

Appendix A.3.4. Map Descriptor Example 2 – Synch the Panel to the FieldServer.

This Read Status Map Descriptor periodically sends a poll to request point information from the Notifier NFS-640/NFS2-640. The offset and length are not used by the driver but must be set to reasonable values to pass driver validation. Nfs\_Clear\_On\_Sys\_Reset is set to 7, and thus Detector, Module and Zone Alarm memory bits will reset on receipt of a “System Reset” message that is generated when the “System Reset” button on the panel is pressed. Note that connection must be via the CRT port.

Map_Descriptor_Name	, Function	, Node_Name	, Address	, Length	, Scan_Interval	, Nfs_Clear_On_Sys_Reset
Read_Status	, Rdbc	, Panel1	, 8888	, 1	, 6000s	, 7

Designates that the Map Descriptor is a Read Status Poll.

There can only be one Node per port. This field indirectly links the FieldServer port to a data storage array. Refer to Section 5.2..

An address of 8888 indicates that this Map Descriptor is a Read Status Poll.

The data contained in the response to this poll is stored in the passive Map Descriptor described in 5.3.3, therefore the length of this Map Descriptor need only be 1.

Scan Interval defines the time between polls.

Appendix A.3.5. Nfs\_Clear\_On\_Sys\_Reset - Settings Table

Setting	Zone Reset
0	All Zones
1	Detector Alarm (0-399)
2	Module Alarm (400-799)
4	Zone Alarms (800-919)
8	Detector Trouble (1000-1399)
16	Module Trouble (1400-1799)
32	Panel Circuit Trouble (1800-1889)
64	Bell Circuit Trouble (1890-1899)
128	Detector Pre-Alarm (2300-2699)
256	System Trouble (4300-4499)
512	Trouble status Zone (4500-4619)
32678	Nothing will reset on “SYSTEM RESET”

If set to the sum of any of the combinations above, all the selected areas will be reset, e.g. if set to 7 = 4+2+1 then Zone alarm(4) , module Alarm(2) and Detector Alarm (1) all will reset.If this keyword is not defined or set to 0 all the above will be reset.

## Appendix B. Troubleshooting

- The Notifier CRT Serial port is disabled by default. If the port is not enabled, the FieldServer receives short (8-9 byte) garbage messages and prints Ic\_Timeout errors for each of these messages. Refer to Appendix A.1 for information on enabling this port.
- If some events are not captured by FieldServer or on "SYSTEM RESET" or "SYSTEM NORMAL" some memory bits are not getting reset at the FieldServer. Check the length of the Data\_Arrays and Server Map\_Descriptors – they should be set to a minimum of 4800.
- If the FieldServer reboots when connected to the Panel Serial port, then it is likely that an Optical Isolator is required to balance ground potential differences. Such differences have been known to damage the FieldServer serial port, and therefore it is recommended that this action is taken as soon as the symptom is observed.

### Appendix B.1. Driver Limitations & Exclusions

This driver depends on the stability of Notifier's CRT and Printer Port messages. Should Notifier modify their message protocol, problems may be experienced with this driver.

The accuracy in recording the Notifier panel status is dependent on synchronization with the FieldServer.

- **For NFS-640:** Upon startup, the FieldServer polls the panel for the status of all points and is then fully synchronized. Event messages sent from the Notifier CRT port will also update the recorded status. Some status changes, e.g. zone information do not result in an explicit message to the CRT port, therefore, the FieldServer's record may not be accurate until the next full read status request.
- **For NFS2-640:** The system reset button on the panel can be pressed to force all existing events to be sent to the FieldServer.

If this driver is connected via the CRT port it cannot support a fire panel connected to a Noti-Fire-Net, as the Network port (NUP port) cannot be used in conjunction with the CRT port.

This driver does not support multi-dropped or networked Notifier panels.

Active event messages such as ALARM: include primary zone information; however, a point device such as a detector or module can be associated with a listing of zones, of which only the first is identified in the message. The status of the zone will be recorded by the driver. For NFS-640/NFS2-640 the status of other zones cannot be updated unless a read point status poll is sent to the panel. Note that this is only possible if connected through the CRT port.

Communication through the CRT port was not designed as a supervised port. Should Notifier wish to make this a supervised port, then this feature can be added to the FieldServer's driver at a later date.

Logic and Evaluating equation status is not recorded by the driver.

A percentage of detector alarms (smoke detectors for instance) is provided in detector status messages but was not implemented in this driver

Appendix C. Reference

Appendix C.1. Message to Data Array Mapping

The primary purpose of this driver is to record the status of devices connected to the Notifier system by interpreting the text messages sent to the RS-232 port. Only messages that directly pertain to device status are recognized. The following table presents the event and read status messages recognized:

Active Events:	Read Point Status:
SYSTEM NORMAL	ON/OFF
ALARM:	NORMAL
TROUBL/CLR TB	ALARM
ACTIVE/CLR ACT	TEST
PREALM/CLR PAL	TBL
DISABL/ENABLE	
TROUBL IN SYSTEM/CLR TB IN SYSTEM	
TEST	
SYSTEM RESET	

- Zone status information will be recorded if incorporated with point status messages.
- TEST read point status messages will change the status of a device in the TROUBL Data Array.
- A detailed mapping of message interaction is tabulated below as well as a current listing of System Trouble messages provided by Notifier at the time this driver was written. Any changes or additions by Notifier will not be reflected in this driver unless specifically revised.

Appendix C.1.1. Panel Status Data Array Mapping

Parameter	Bits	Parameter	Bits
Detector Alarm (loop 1) (loop 2) eg 2D001 -> 201	0-199 200-399	Module Alarm (loop1) (loop2)	400-599 600-799
Zone Alarms (software) (special) (releasing) eg Z01 -> 801 F07 -> 907 R00 -> 910	800-899 900-909 910-919	Panel Circuit Trouble eg P1.1 -> 1811 P8.8 -> 1888	1800-1889
Detector Trouble (loop 1) (loop 2)	1000-1199 1200-1399	Module Trouble (loop 1) (loop 2)	1400-1599 1600-1799
Bell Circuit Trouble eg B01 -> 1891 B04 -> 1894	1890-1899	Active Monitor Modules (loop1) (loop2)	1900-2099 2100-2299
Detector Pre-Alarm (loop 1) (loop 2)	2300-2499 2500-2699	Detector Disable (loop 1) (loop 2)	2700-2899 2900-3099

Parameter	Bits	Parameter	Bits
Module Disable (loop 1) (loop 2)	3100-3299 3300-3499	On/Off status Module (loop 1) (loop 2)	3600-3799 3800-3999
Panel Circuit Disable	3500-3589	Bell Circuit Disable	3590-3599
On/Off status Panel Circuit	4000-4089	On/Off status Bell Circuit	4090-4099
On/Off status Zone (software) (special) (releasing)	4100-4199 4200-4209 4210-4219	SystemTrouble 4499 = unknown system trouble 4300+ = listed system troubles	4300-4499
Trouble status Zone (software) (special) (releasing)	4500-4599 4600-4609 4610-4619	Disable Zone (software)	4700-4799

### Appendix C.1.2. Calculating Array Offset for a Given Detector/Module/Zone etc.

**Example 1:** Detector 1 on loop 1 reports as being in alarm.

Detector alarms are stored in 0-399.

Loop 1 detectors are stored in 0-199.

Detector 1 is stored at offset 1. (2<sup>nd</sup> element in the array).

**Example 2:** Detector 2 on loop 1 reports as being in alarm.

Detector alarms are stored in 0-399.

Loop 1 detectors are stored in 0-199.

Detector 2 is stored at offset 2. (3<sup>rd</sup> element in the array.)

**Example 3:** Detector 2 on loop 2 reports as being in pre-alarm.

Detector pre-alarms are stored in 2300-23699.

Loop 2 detectors are stored in 2500-2699.

Detector 2 is stored at offset 2502. (2503<sup>rd</sup> element in the array)

**Example 4:** Special Zone #3 reports as being in alarm.

Zone alarms are stored in 800-919.

Special zones are stored in 900-909.

Special zone #3 alarm status is stored at offset 903. (904th element in the array.)

**Example 5:** The panel reports that the panel door is open.

Using the table in Appendix C.3 to look up the offset for this message. The relative offset is 12.

Using Appendix C.1.1 : System alarms are stored at offsets 4300-4499.

Thus the door open status is stored at offset 4312 (the 4313rd element in the array).

Appendix C.2. Notifier NFS-640 Message Types Recognized

	Initiating Function	Status Banner	Data Array	Indication of Clear	Notes:
1	Scheduled function of the NFS-640 panel, or after a reset	SYSTEM NORMAL	N/A	N/A	
2	detector or module activates	ALARM: or ALARM	D(2X159) M(2X159) Z(99) F(10) R(10)	SYSTEM NORMAL And SYSTEM RESET	Will also set zone alarm array
3	detector or module has an electrical or mechanical fault	TROUBL or TEST	D(2X159) M(2X159) Panel(9X9) Bell(4)	CLR TB And SYSTEM NORMAL And SYSTEM RESET	Clear is sent automatically by panel, then system normal is sent if criteria in 2 above is met
4	monitor module programmed with security code activates	ACTIVE	M(2X159)	SYSTEM NORMAL	Will also set zone alarm array
5	monitor module programmed with supervisory code activates	ACTIVE	same array as 5 above	SYSTEM NORMAL	
6	detector exceeds programmed pre-alarm alert or action level	PREALM	D(2X159)	SYSTEM NORMAL or CLR PAL And SYSTEM RESET	Action pre-alarms need to be reset Alert pre-alarms reset themselves and sends sys normal CLEAR not implemented
7	detector, monitor module, control/relay module or panel circuit has been disabled	DISABL	D(2X159) M(2X159) Panel(9X9) Bell(4)  Z(99)	ENABLE or SYSTEM NORMAL or CLR TB	Note can also DISABL zone <b>Note</b> only software zones can be disabled from the panel
8	monitor modules programmed with non-alarm codes	ACTIVE	same array as 5 above	CLR ACT  SYSTEM NORMAL	
9	monitor modules programmed with equipment trouble codes	TROUBL	same array as 4 above	SYSTEM NORMAL And SYSTEM RESET	when corrected panel removes trouble automatically and sends system normal
10	Trouble on output circuits for NAC's, panel circuits, or control/relay modules	TROUBL	same arrays as 4 above	SYSTEM NORMAL And SYSTEM RESET	When corrected panel removes trouble automatically and sends system normal
11	read point status of monitor module, NAC=bell, panel, software zone 'Z', special zone 'F', or releasing zone 'R'	ON	M(2X159) B(4) P(8X8) Z(99) F(10) R(10)	OFF or NORMAL or SYSTEM NORMAL	

	Initiating Function	Status Banner	Data Array	Indication of Clear	Notes:
12	read point status of a detector	ALARM TEST	same array as 3,4 above  ALARM will set alarm point, and zone array  TEST will set trouble array for point only  ALARM will set alarm array,  TEST will set trouble array	NORMAL  or  SYSTEM NORMAL	
13	system has trouble see protocol spec appendix B-3	TROUBL IN SYSTEM	ST(200)	CLR TB IN SYSTEM SYSTEM NORMAL And SYSTEM RESET	see attached table for system trouble messages
14	from read point status	NORMAL	should clear  detector: alarm trouble disable <i>prealarm</i> module: alarm trouble disable <i>active on</i>		
15	from read point status	ON	ON affects: module_on bell_on panel_on z_on f_on r_on  ON ignores: evaluation and logic equations in read point status	OFF or NORMAL or SYSTEM NORMAL	

	Initiating Function	Status Banner	Data Array	Indication of Clear	Notes:
16	from read point status	OFF	<p>these clear different parts of the array depending on the device or zone:</p> <p>module (control/relay): on disable alarm active</p> <p>panel: on disable</p> <p>bell: on disable</p> <p>zone: on disable(for software only!) alarm tbl</p>		<p>TROUBL arrays except for zone TBL are not affected by OFF.</p> <p>The trouble, clr trouble messages, system normal are expected to clear the TROUBL points</p>
17	from read point status	TBL	<p>sets zone trouble array or sets control/relay module array but not monitor modules</p>		<p>note: TROUBL sets detector, monitor module, panel, and bell TBL ignores evaluation and logic equations</p>
18	clear trouble	CLR TB	<p>resets TROUBL array for D,M,P,B and resets DISABL array for D, M, P, B</p>		<p>When a zone is disabled, the corresponding points are also disabled When a zone is enabled, the zone message is ENABLE, but for the points is CLR TB</p>
19		ENABLE	resets DISABL		

Appendix C.3. System Trouble Messages

message	#	Panel Status Data Array Offset
"GROUND FAULT"	0	4300
"AC FAIL"	1	4301
"BATTERY"	2	4302
"STYLE 6 POS. LOOP 1"	3	4303
"STYLE 6 POS. LOOP 2"	4	4304
"CORRUPT LOGIC EQUAT"	5	4305
"LCD80 SUPERVISORY"	6	4306
"EPROM ERROR"	7	4307
"INTERNAL RAM ERROR"	8	4308
"EXTERNAL RAM ERROR"	9	4309
"PROGRAM CORRUPTED"	10	4310
"NO DEV. INST ON L1"	11	4311
"PANEL DOOR OPEN"	12	4312
"AUXILIARY TROUBLE"	13	4313
"TERM. SUPERVISORY"	14	4314
"ANNUN. 1 TROUBLE"	15	4315
"ANNUN. 1 NO ANSWER"	16	4316
"ANNUN. 2 TROUBLE"	17	4317
"ANNUN. 2 NO ANSWER"	18	4318
"ANNUN. 3 TROUBLE"	19	4319
"ANNUN. 3 NO ANSWER"	20	4320
"ANNUN. 4 TROUBLE"	21	4321
"ANNUN. 4 NO ANSWER"	22	4322
"ANNUN. 5 TROUBLE"	23	4323
"ANNUN. 5 NO ANSWER"	24	4324
"ANNUN. 6 TROUBLE"	25	4325
"ANNUN. 6 NO ANSWER"	26	4326
"ANNUN. 7 TROUBLE"	27	4327
"ANNUN. 7 NO ANSWER"	28	4328
"ANNUN. 8 TROUBLE"	29	4329
"ANNUN. 8 NO ANSWER"	30	4330
"ANNUN. 9 TROUBLE"	31	4331
"ANNUN. 9 NO ANSWER"	32	4332

message	#	Panel Status Data Array Offset
"ANNUN.10 TROUBLE"	33	4333
"ANNUN.10 NO ANSWER"	34	4334
"ANNUN.11 TROUBLE"	35	4335
"ANNUN.11 NO ANSWER"	36	4336
"ANNUN.12 TROUBLE"	37	4337
"ANNUN.12 NO ANSWER"	38	4338
"ANNUN.13 TROUBLE"	39	4339
"ANNUN.13 NO ANSWER"	40	4340
"ANNUN.14 TROUBLE"	41	4341
"ANNUN.14 NO ANSWER"	42	4342
"ANNUN.15 TROUBLE"	43	4343
"ANNUN.15 NO ANSWER"	44	4344
"ANNUN.16 TROUBLE"	45	4345
"ANNUN.16 NO ANSWER"	46	4346
"ANNUN.17 TROUBLE"	47	4347
"ANNUN.17 NO ANSWER"	48	4348
"ANNUN.18 TROUBLE"	49	4349
"ANNUN.18 NO ANSWER"	50	4350
"ANNUN.19 TROUBLE"	51	4351
"ANNUN.19 NO ANSWER"	52	4352
"ANNUN.20 TROUBLE"	53	4353
"ANNUN.20 NO ANSWER"	54	4354
"ANNUN.21 TROUBLE"	55	4355
"ANNUN.21 NO ANSWER"	56	4356
"ANNUN.22 TROUBLE"	57	4357
"ANNUN.22 NO ANSWER"	58	4358
"ANNUN.23 TROUBLE"	59	4359
"ANNUN.23 NO ANSWER"	60	4360
"ANNUN.24 TROUBLE"	61	4361
"ANNUN.24 NO ANSWER"	62	4362
"ANNUN.25 TROUBLE"	63	4363
"ANNUN.25 NO ANSWER"	64	4364
"ANNUN.26 TROUBLE"	65	4365

essage	#	Panel Status Data Array Offset
"ANNUN.26 NO ANSWER"	66	4366
"ANNUN.27 TROUBLE"	67	4367
"ANNUN.27 NO ANSWER"	68	4368
"ANNUN.28 TROUBLE"	69	4369
"ANNUN.28 NO ANSWER"	70	4370
"ANNUN.29 TROUBLE"	71	4371
"ANNUN.29 NO ANSWER"	72	4372
"ANNUN.30 TROUBLE"	73	4373
"ANNUN.30 NO ANSWER"	74	4374
"ANNUN.31 TROUBLE"	75	4375
"ANNUN.31 NO ANSWER"	76	4376
"ANNUN.32 TROUBLE"	77	4377
"ANNUN.32 NO ANSWER"	78	4378
"NETWORK FAIL PORT A"	79	4379
"NETWORK FAIL PORT B"	80	4380
"NCM COMM FAILURE"	81	4381
"ADV WALK TEST"	82	4382
"CHARGER FAIL"	83	4383
"GROUND FAULT LOOP2"	84	4384
"STYLE 6 NEG. LOOP 1"	85	4385
"STYLE 6 NEG. LOOP 2"	86	4386
"GROUND FAULT LOOP1"	87	4387
"UDACT TROUBLE"	88	4388
"UDACT NO ANSWER"	89	4389
"PROG MODE ACTIVATED"	90	4390
"LOADING..NO SERVICE"	91	4391
"BASIC WALK TEST"	92	4392
"NFPA 24Hr. REMINDER"	93	4393
"BAT. BACKUP RAM"	94	4394
"Master Box trouble"	95	4395
"Detector Initialize"	96	4396
"Pwr.Supply Comm Fail"	97	4397
"Release Dev. Disable"	98	4398

essage	#	Panel Status Data Array Offset
"DVC Ext Ram Error"	99	4399
"DVC Program Corrupt"	100	4400
"DVC Loading No Serv"	101	4401
"DVC NVRam Batt Tbl"	102	4402
"DVC Buzzer Off-Line"	103	4403
"DVC Self Test Fail"	104	4404
"DVC Soft. Mismatch"	105	4405
"DVC Aux.Trouble"	106	4406
"DVC FFT Trouble"	107	4407
"Drill activated"	108	4408
"Network Incompatible"	109	4409
"DVC Rem. Mic. Tbl."	110	4410
"DVC Local Mic. Tbl."	111	4411
"DVC Local Phone Tbl"	112	4412
"DVC Analog Out.1 Tbl"	113	4413
"DVC Analog Out.2 Tbl"	114	4414
"DVC Analog Out.3 Tbl"	115	4415
"DVC Analog Out.4 Tbl"	116	4416
"DVC Flash Image Err"	117	4417
"DVC Database Corrupt"	118	4418
"DVC Audio Lib.Corrupt"	119	4419
"DVC Dbase Incompat"	120	4420
"DVC Audio Lib Incomp"	121	4421
"DVC DAA Downloading"	122	4422
"HS_NCM Sniffer Activ"	123	4423
"Exceeded Conn. Limit"	124	4424

## Appendix C.4. Driver Error Messages

Most error messages are associated with errors in parsing an incoming message from the NFS-640. The most likely cause is a mismatch in expected message format. The driver will flag one of the following error messages and continue.

Timeout Errors are related to a lack of response by the Notifier panel to read poll status polls, or due to internal timing anomalies of the FieldServer. If a Timeout error message is displayed then the error is most likely external. Check your connections.

Checksum Errors are recorded for messages that are incomplete. Review the message that was discarded, and call support if this event occurs repeatedly, or if the message was incorrectly ignored.

The following table lists possible error messages produced by this driver.

Error Message	Corrective Action
NFS640#2: Err. Illegal Map Descriptor length - defaulting to 1	check configuration file settings
NFS640#3: Err. Diagnostic line ignored.	call support, developers diagnostic
NFS640#4: Err. Test file <%s> not found.	call support, developers diagnostic
NFS640#5: Err. parsing NORMAL	See Note 1.
NFS640#6: Err. storing NORMAL	See Note 1.
NFS640#7: Err. parsing ALARM:	See Note 1.
NFS640#8: Err. parsing ALARM:	See Note 1.
NFS640#9: Err. storing ALARM:	See Note 1.
NFS640#10: Err. parsing ACTIVE	See Note 1.
NFS640#11: Err. storing ACTIVE	See Note 1.
NFS640#12: Err. parsing CLR ACT	See Note 1.
NFS640#13: Err. storing CLR ACT	See Note 1.
NFS640#14: Err. parsing PREALM	See Note 1.
NFS640#15: Err. storing PREALM	See Note 1.
NFS640#16: Err. parsing CLR PAL	See Note 1.
NFS640#17: Err. storing CLR PAL	See Note 1.
NFS640#18: Err. parsing DISABL	See Note 1.
NFS640#19: Err. storing DISABL	See Note 1.
NFS640#20: Err. parsing ENABLE	See Note 1.
NFS640#21: Err. storing ENABLE	See Note 1.
NFS640#22: Err. parsing ON	See Note 1.
NFS640#23: Err. storing ON	See Note 1.
NFS640#24: Err. parsing OFF	See Note 1.
NFS640#25: Err. storing OFF	See Note 1.
NFS640#26: Problems parsing TROUBL IN SYSTEM, recorded as 'unknown' trouble	See Note 1.
NFS640#27: Err. storing TROUBL IN SYSTEM	See Note 1.
NFS640#28: Err. parsing CLR TB IN SYSTEM	See Note 1.
NFS640#29: Err. storing CLR TB IN SYSTEM	See Note 1.

Error Message	Corrective Action
NFS640#30: Err. parsing TROUBL or TEST	See Note 1.
NFS640#31: Err. storing TROUBL or TEST	See Note 1.
NFS640#32: Err. parsing CLR TB	See Note 1.
NFS640#33: Err. storing CLR TB	See Note 1.
NFS640:#34 Err. Incoming data is being abandoned on port %d. MapDesc's are required to define storage.	Check that the Notifier is connected to the correct serial port defined in the csv's
NFS640#35: Err. parsing TBL	See note 1.
NFS640#36: Err. storing TBL	See note 1.
NFS640#37: Warning. Incomplete message.	review message and call support if necessary
NFS640#38: Err. No response to read point status poll	Check connections to the Notifier panel, call support if message persists. Note, the Notifier panel will not respond if in programming mode, so some no response messages may occur if the FieldServer polls the Notifier panel in this mode. This functionality is only possible if connected through the CRT port.
NFS640#39: FYI. Defaulting MD scan_interval to 10 min	If required update config if with appropriate scan_interval
NFS640#40: FYI. Minimum recommended scan_interval is %ds	

**Note 1:** These errors are produced when the driver is unable to parse a message correctly. This could happen if 1) the message is corrupted or 2) the message contains keywords not recognized by the driver or the message structure is different to what was expected. If the cause is the latter then you need to take a log and send the log together with your configuration CSV file when reporting this problem to tech support. If you get one of these errors on rare occasions then the source of the error is likely to be a corrupted message.

### Appendix C.5. FieldServer Statistics

The following table identifies statistics generated by the Notifier Onyx NFS-640 serial driver and their meanings.

Message	Meaning
Read message sent	Total number of messages sent for reading the status of all Notifier panel points. Each time an active poll is made, expect this stat to increase by 2 as the protocol requires two messages to complete this request.
Bytes sent	Total number of bytes sent by all read point status polls to the Notifier panel.
Message received	Total number messages of all types received from the Notifier panel A message is a single line reporting status.
Bytes received	Total number of bytes received by all message types from the Notifier panel.
Ignored messages	Total number of messages ignored by the driver because an appropriate Map Descriptor could not be found or the type of message is not currently relevant.
IC timeout Errors	Total number of inter-character timeouts that have occurred.
Protocol Errors	A message could not be parsed or stored correctly.