



A Sierra Monitor Company

Driver Manual
(Supplement to the FieldServer Instruction Manual)

FS-8700-60 Gardner Denver Auto Sentry ES/RS2000

APPLICABILITY & EFFECTIVITY

Effective for all systems manufactured after August 2011

Driver Version: 1.03
Document Revision: 2

TABLE OF CONTENTS

1	Gardner Denver Auto Sentry ES/RS2000 Description	3
2	Driver Scope of Supply	4
2.1	Supplied by FieldServer Technologies for this driver.....	4
2.2	Provided by the Supplier of 3 rd Party Equipment	4
2.2.1	<i>Required 3rd Party Hardware</i>	<i>4</i>
2.2.2	<i>Required 3rd Party Configuration</i>	<i>4</i>
2.2.3	<i>Optional Items</i>	<i>4</i>
3	Hardware Connections.....	5
3.1	Hardware Connection Tips / Hints.....	5
4	Data Array Parameters.....	6
5	Configuring the FieldServer as a Gardner Denver Auto Sentry ES/RS2000 Client.....	7
5.1	Client Side Connection Parameters	7
5.2	Client Side Node Parameters	7
5.3	Client Side Map Descriptor Parameters.....	8
5.3.1	<i>FieldServer Specific Map Descriptor Parameters</i>	<i>8</i>
5.3.2	<i>Driver Related Map Descriptor Parameters.....</i>	<i>8</i>
5.3.3	<i>Timing Parameters.....</i>	<i>8</i>
5.3.4	<i>Map Descriptor Example 1 – Polling all available Controller Data</i>	<i>9</i>
5.3.5	<i>Map Descriptor Example 2 - Polling specific data items.....</i>	<i>9</i>
5.3.6	<i>Map Descriptor Example 3 - Polling all data and isolating specific data items</i>	<i>9</i>
Appendix A.	Useful Features.....	10
Appendix A.1.	Method used to Isolate Specific Items	10
Appendix A.2.	Poll Data Length	10
Appendix B.	Troubleshooting.....	11
Appendix B.1.	No response to select unit polls for single units connected.....	11
Appendix C.	Reference.....	12
Appendix C.1.	Data Storage Format	12

1 GARDNER DENVER AUTO SENTRY ES/RS2000 DESCRIPTION

The Gardner Denver Auto Sentry ES/RS2000 driver allows the FieldServer to transfer data from devices over either RS-232 or RS-485 using Gardner Denver Auto Sentry ES/RS2000 protocol. The driver can be configured to communicate with ES Controllers with software versions V2.0X, V2.1X and RS2000 Controllers with software versions V4.0X

The client driver implements the following functionality:

- Polls controllers for service and maintenance data.
- Polls controllers for operating mode data.
- Polls controllers for operating data.

The driver can poll up to 8 units connected to one ES/RS2000 Controller. It always sets the active unit on the ES/RS2000 Controller before polling for data even if consecutive polls are for the same unit. This is done to prevent synchronization problems.

Gardner Denver ES/RS2000 Controllers implements three message types for which the driver can poll. The driver does not validate the message data fields for correct values although it does validate data field lengths. For example, shutdown codes reported by V2.1 ES Controllers range from 0 to 27. If a code of 28 is reported, the driver will not flag it as an error since codes have to be interpreted by the operator. However, a message length longer than 2 digits will be reported as an error.

Max Nodes Supported

FieldServer Mode	Nodes	Comments
Client	1	A client node can communicate with up to 8 units connected to a ES/RS2000 Controller

2 DRIVER SCOPE OF SUPPLY

2.1 Supplied by FieldServer Technologies for this driver

FieldServer Technologies PART #	Description
FS-8915-10	UTP cable (7 foot) for RS-232 use
FS-8917-03	RJ45 to DB9M connector adapter

2.2 Provided by the Supplier of 3rd Party Equipment

2.2.1 Required 3rd Party Hardware

Part #	Description
-	ES/RS2000 controller

2.2.2 Required 3rd Party Configuration

The ES/RS2000 Controller must be set up in the correct mode to support either RS-232 or RS-485 communications to an external monitoring system. Please refer to manufacturer's setup instructions.

2.2.3 Optional Items

PART #	Vendor/Manufacturer	Description
485LDRC	B&B Electronics	RS-232/RS-485 converter

3 HARDWARE CONNECTIONS

The FieldServer is connected to the ES/RS2000 Controller as shown in the connection drawing below:

Configure the ES/RS2000 Controller according to manufacturer’s instructions.

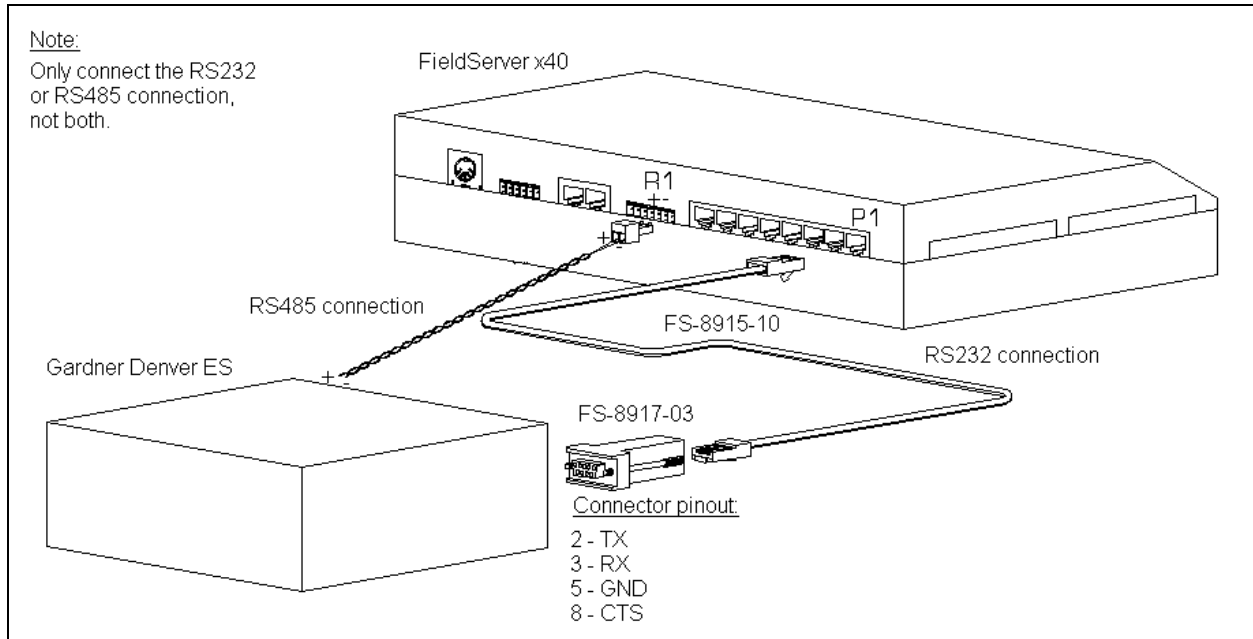

3.1 Hardware Connection Tips / Hints

- If inter-controller communications are set up for the controller, connect to the RS-232 port only.
- If inter-controller communications are not used, connect to either the RS-232 or RS-485 port of the Controller.

4 DATA ARRAY PARAMETERS

Data Arrays are “protocol neutral” data buffers for storage of data to be passed between protocols. It is necessary to declare the data format of each of the Data Arrays to facilitate correct storage of the relevant data.

Section Title		
Data_Arrays		
Column Title	Function	Legal Values
Data_Array_Name	Provide name for Data Array	Up to 15 alphanumeric characters
Data_Array_Format	Provide data format. Each Data Array can only take on one format.	FLOAT, BIT, UInt16, SInt16, Byte.
Data_Array_Length	Number of Data Objects. Must be larger than the data storage area required by the Map Descriptors for the data being placed in this array.	1-10,000

Example

```
// Data Arrays
Data_Arrays
Data_Array_Name , Data_Array_Format , Data_Array_Length
DA_Service_Data , UInt32 , 38
DA_Oper_Mode , UInt16 , 3
DA_Oper_Data , UInt16 , 5
```

5 CONFIGURING THE FIELDSEVER AS A GARDNER DENVER AUTO SENTRY ES/RS2000 CLIENT

For a detailed discussion on FieldServer configuration, please refer to the FieldServer Configuration Manual. The information that follows describes how to expand upon the factory defaults provided in the configuration files included with the FieldServer (See “.csv” sample files provided with the FieldServer). This section documents and describes the parameters necessary for configuring the FieldServer to communicate with a Gardner Denver Auto Sentry ES/RS2000 Controller.

5.1 Client Side Connection Parameters

Section Title		
Connections		
Column Title	Function	Legal Values
Port	Specify which port the device is connected to the FieldServer	P1-P8, R1-R2 ¹
Protocol	Specify protocol used	Gardner_Denver
Baud*	Specify baud rate	1200, 9600 (match to Controller)
Parity*	Specify parity	Odd, Even, None
Data_Bits*	Specify data bits	7, 8
Stop_Bits*	Specify stop bits	1, 2
Poll_Delay*	Time between internal polls	≥0.2s, 0.2s
Timeout*	Time to wait for response	≥0.6s, 0.6s

Example

```
// Client Side Connections

Connections
Port , Protocol
P1 , Gardner_Denver
```

5.2 Client Side Node Parameters

Section Title		
Nodes		
Column Title	Function	Legal Values
Node_Name	Provide name for node	Up to 32 alphanumeric characters
Node_ID	Unit number connected to an ES/RS2000 controller	1-8
Protocol	Specify protocol used	Gardner_Denver
Connection	Specify which port the device is connected to the FieldServer	P1-P8, R1-R2 ¹
Node_Type*	Sets the protocol to be used for different Controller software versions	ES V2.0X ES V2.1X RS2000 V4.0X

¹ Not all ports shown are necessarily supported by the hardware. Consult the appropriate Instruction manual for details of the ports available on specific hardware.

Example

```
// Client Side Nodes

Nodes
Node_Name , Node_ID , Protocol , Connection
Node_1 , 1 , Gardner_Denver , P1
Node_2 , 2 , Gardner_Denver , P1
```

5.3 Client Side Map Descriptor Parameters

5.3.1 FieldServer Specific Map Descriptor Parameters

Column Title	Function	Legal Values
Map_Descriptor_Name	Name of this Map Descriptor	Up to 32 alphanumeric characters
Data_Array_Name	Name of Data Array where data is to be stored in the FieldServer	One of the Data Array names from Section 4
Data_Array_Offset	Starting location in Data Array	0 to (Data_Array_Length-1) as specified in Section 4.
Function	Function of Client Map Descriptor	RDBC, Passive_Client

5.3.2 Driver Related Map Descriptor Parameters

Column Title	Function	Legal Values
Node_Name	Name of Node to fetch data from	One of the Node names specified in Section 5.2
Gar_Cmd	Data poll commands	Service_Data, Operating_Mode, Operating_Data
Gar_Data*	Data fields in a data poll command response message. Can be used to poll for all or specific data or just isolate specific items in an "All" poll.	Service_Data: All, Advisories, Shutdown_codes, Hourmeter_shutdown, Hourmeter_total, Hourmeter_loaded, Hourmeter_temp, Hourmeter_tmp_st, Last_maint_A, Last_maint_B, Oilage Operating_Mode: All, Oper_mode, Seq_number, Oper_state Operating_Data: All, System_pressure, Filter_pressure, Discharge_temp, Reservoir_temp, Motor_current

5.3.3 Timing Parameters

Column Title	Function	Legal Values
Scan_Interval*	Rate at which data is polled. Note that the Poll_Delay Connection parameter affects the effective scan interval.	≥0.1s, 0.1s

5.3.4 Map Descriptor Example 1 – Polling all available Controller Data

Map_Descriptor_Name	Data_Array_Name	Data_Array_Offset	Function	Node_Name	Gar_Cmd	Gar_Data	Scan_Interval
GD_MBA1	, DA_Service_Data	, 0	, RDBC	, Node_1	, Service_Data	, All	, 1.0s
GD_MBA2	, DA_Oper_Mode	, 0	, RDBC	, Node_1	, Operating_Mode	, All	, 1.0s
GD_MBA3	, DA_Oper_Data	, 0	, RDBC	, Node_1	, Operating_Data	, All	, 1.0s

Active Read Block Continuous Map Descriptor function responsible for polling the Controller.

The Gar_Cmd field is used to select the data to poll

The Gar_data field is set to "All" indicating that all available data is polled

5.3.5 Map Descriptor Example 2 - Polling specific data items

Map_Descriptor_Name	Data_Array_Name	Data_Array_Offset	Function	Node_Name	Gar_Cmd	Gar_Data	Scan_Interval
GD_MBA1	, DA_Hourmeter	, 0	, RDBC	, Node_1	, Service_Data	, Hourmeter_total	, 1.0s
GD_MBA2	, DA_Oper_Mode	, 0	, RDBC	, Node_1	, Operating_Mode	, Oper_mode	, 1.0s
GD_MBA3	, DA_Motor_Amps	, 0	, RDBC	, Node_1	, Operating_Data	, Motor_current	, 1.0s

Note the active Read Block Continuous map descriptor function responsible for polling the Controller.

The Gar_Cmd field is used to select the data to poll

The Gar_data field is set to "Motor_current" indicating that only this data item will be stored.

5.3.6 Map Descriptor Example 3 - Polling all data and isolating specific data items

Map_Descriptor_Name	Data_Array_Name	Data_Array_Offset	Function	Node_Name	Gar_Cmd	Gar_data	Scan_Interval
GD_MBA1	, DA_Service_Data	, 0	, RDBC	, Node_1	, Service_Data	, All	, 1.0s
GD_MBA2	, DA_Oilage	, 0	, Passive_Client	, Node_1	, Service_Data	, Oilage	, -
GD_MBA3	, DA_Hourmeter	, 0	, Passive_Client	, Node_1	, Service_Data	, Hourmeter_total	, -
GD_MBA4	, DA_Oper_Mode	, 0	, RDBC	, Node_1	, Operating_Mode	, All	, 1.0s
GD_MBA5	, DA_Oper_State	, 0	, Passive_Client	, Node_1	, Operating_Mode	, Oper_state	, -
GD_MBA6	, DA_Oper_Data	, 0	, RDBC	, Node_1	, Operating_Data	, All	, 1.0s
GD_MBA7	, DA_Disch_Temp	, 0	, Passive_Client	, Node_1	, Operating_Data	, Discharge_temp	, -

The Passive_Client Map Descriptor does not poll but receives data from the active map descriptor where the Gar_Cmd and Node_Name fields match.

The Gar_Cmd field is used to select the data to poll

The specific data item, "Discharge_temp" is isolated here by using the same Gar_Cmd as the active map descriptor.

Appendix A. Useful Features

Appendix A.1. Method used to Isolate Specific Items

A Passive_Client Map Descriptor must be used after an active RDBC Map Descriptor. The driver uses the Active Map Descriptors to poll the Controller and then searches for Passive Client Map Descriptors with matching Node_Name and Gar_Cmd fields. It then stores the data items as specified by the Gar_data field from the data collected by the preceding active Map Descriptor.

Appendix A.2. Poll Data Length

The length of the data packet retrieved from the Controller during a poll is always fixed for each of the three types of data polls. When specifying a specific Gar_Data item using a RDBC active Map Descriptor, the driver receives all data of Gar_Cmd type from the controller in a single poll, but only stores the data item in question.

Appendix B. Troubleshooting

Appendix B.1. No response to select unit polls for single units connected

The device must be in “Sequence Mode”, not Standalone mode. The unit can be put in sequence mode setting the “Units in Sequence” to a number greater than 1.

If using sequence mode is not feasible for the application, please contact FieldServer Technologies for a solution

Appendix C. Reference

Appendix C.1. Data Storage Format

Offset	Description	Units
DA_Service_Data		
0	Advisories	see ES/RS2000 Controller spec
1-20	10x (Shutdown code / Hourmeter reading) pairs	see ES/RS2000 Controller spec
21	Current total runtime hourmeter reading	Hours
22	Current loaded runtime hourmeter reading	Hours
23-28	6x Current temp hourmeters [H1] – [H6]	Hours
29-34	6x Stored temp hourmeters [OH1] – [OH6]	Hours
35	Last maintenance A	Hours
36	Last maintenance B	Hours
37	Oilage	Unknown, see ES/RS2000 controller spec
Operating mode data		
0	Operating mode indication	see ES/RS2000 Controller spec
1	Sequence number ²	see ES/RS2000 Controller spec
2	Unit operating state ³	see ES/RS2000 Controller spec
Operating data		
0	System pressure	divide by 16 for pressure in psig
1	Filter pressure	divide by 16 for pressure in psig
2	Discharge temperature	divide by 16 for temperature in degrees F
3	Reservoir temperature	divide by 16 for temperature in degrees F
4	Motor current ⁴	amps

² ES V2.0X Controllers do not respond with this field

³ ES V2.0X Controllers do not respond with this field

⁴ RS2000 V4.0X Controllers set this field to zero