



A Sierra Monitor Company

Driver Manual
(Supplement to the FieldServer Instruction Manual)

FS-8700-14 GE Mark IV Speedtronic

APPLICABILITY & EFFECTIVITY

Effective for all systems manufactured after April 2010

Driver Version: 1.00
Document Revision: 7

TABLE OF CONTENTS

1 GE Mark IV Speedtronic Description 3

2 Driver Scope of Supply 3

 2.1 Supplied by FieldServer Technologies for this driver 3

3 Hardware Connections..... 4

4 Data Array Parameters..... 5

5 Configuring the FieldServer as a GE Mark IV Speedtronic Passive Client 6

 5.1 Client Side Connection Descriptions6

 5.2 Client Side Node Descriptors7

 5.3 Client Side Map Descriptors.....7

 5.3.1 *FieldServer Related Map Descriptor Parameters*7

 5.3.2 *Driver Related Map Descriptor Parameters*.....7

 5.3.3 *Map Descriptor Example*.....8

Appendix A. Reference 9

 Appendix A.1. Driver Point List9

1 GE MARK IV SPEEDTRONIC DESCRIPTION

The GE Mark IV Speedtronic driver allows the FieldServer to receive status data from Speedtronic devices over either RS-232 or RS-485 using GE Mark IV Speedtronic protocol. The Driver acts as a Passive Client and receives status data from Speedtronic devices. Note that only Digital values are supported.

Max Nodes Supported

FieldServer Mode	Nodes	Comments
Passive Client	1-10 (max)	The max number of nodes is limited by the amount of physical ports on the FieldServer.

2 DRIVER SCOPE OF SUPPLY

2.1 Supplied by FieldServer Technologies for this driver

FieldServer Technologies PART #	Description
FS-8915-10	UTP Cable (7-Foot) For RS-232 Use
FS-8917-09	RJ45 To DB25F Connection Adapter (8915-04)
FS-8700-14	Driver Manual.

3 HARDWARE CONNECTIONS

Configure the GE Mark IV Speedtronic according to manufacturer’s instructions

The FieldServer is connected to the GE Mark IV Speedtronic as shown below.

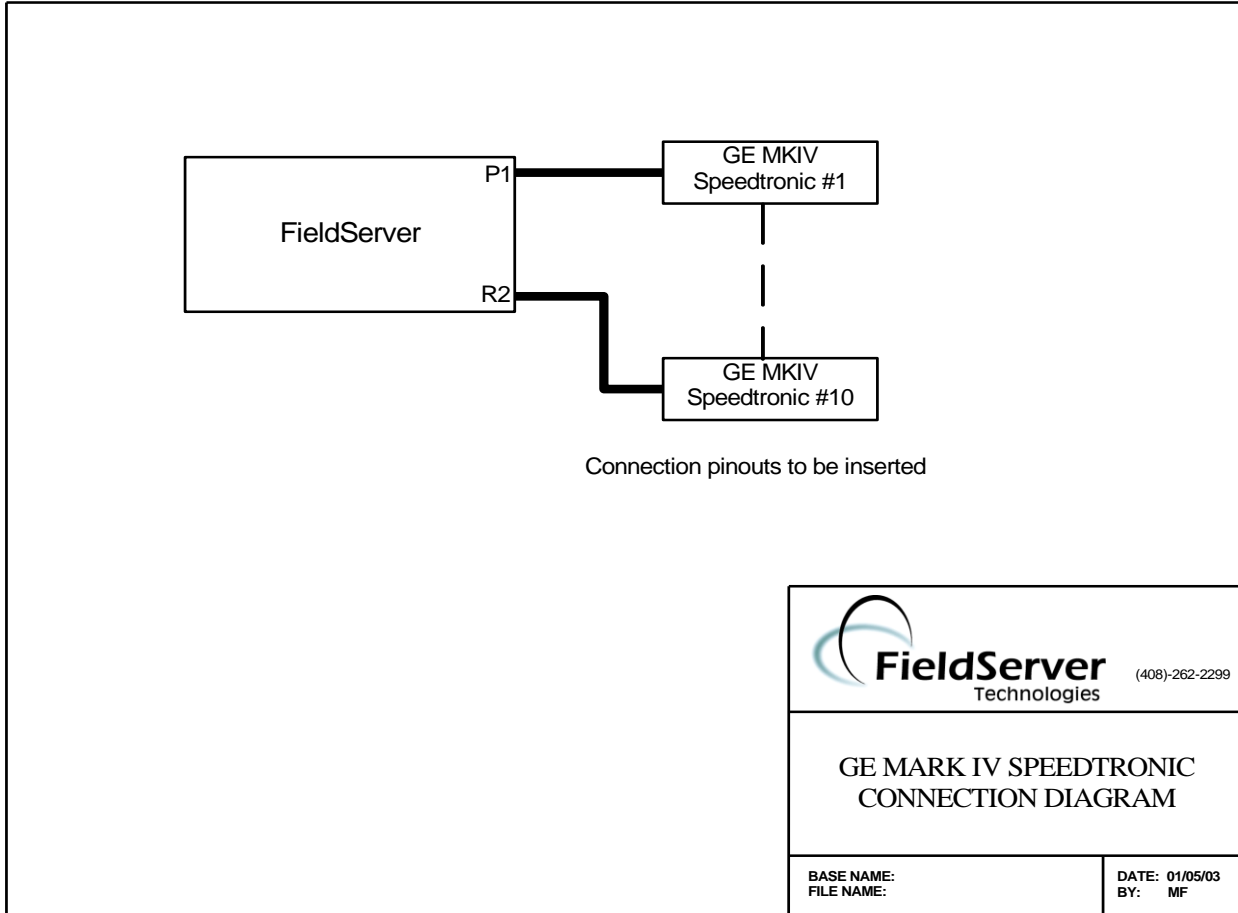

4 DATA ARRAY PARAMETERS

Data Arrays are “protocol neutral” data buffers for storage of data to be passed between protocols. It is necessary to declare the data format of each of the Data Arrays to facilitate correct storage of the relevant data.

Section Title		
Data_Arrays		
Column Title	Function	Legal Values
Data_Array_Name	Provide name for Data Array	Up to 15 alphanumeric characters
Data_Array_Format	Provide data format. Each Data Array can only take on one format.	FLOAT, BIT, UInt16, Sint16, Byte.
Data_Array_Length	Number of Data Objects. Must be larger than the data storage area required by the Map Descriptors for the data being placed in this array.	1-10,000

Example

```
// Data Arrays
Data_Arrays
Data_Array_Name , Data_Array_Format , Data_Array_Length
GE_Status_Data , Byte , 253
```

5 CONFIGURING THE FIELDSEVER AS A GE MARK IV SPEEDTRONIC PASSIVE CLIENT

For a detailed discussion on Fieldserver configuration, please refer to the Fieldserver Configuration Manual. The information that follows describes how to expand upon the factory defaults provided in the configuration files included with the FieldServer (See “.csv” sample files provided with the FieldServer).

This section documents and describes the parameters necessary for configuring the Fieldserver to communicate with GE Mark IV Speedtronic devices.

The configuration file tells the Fieldserver about its interfaces, and the routing of data required. In order to enable the Fieldserver for GE Mark IV Speedtronic communications, the driver independent Fieldserver buffers need to be declared in the “Data Arrays” section, the destination device addresses need to be declared in the “Client Side Nodes” section, and the data required from the servers needs to be mapped in the “Client Side Map Descriptors” section. Details on how to do this can be found below.

Note that in the tables, * indicates an optional parameter, with the bold legal value being the default.

5.1 Client Side Connection Descriptions

Section Title		
Column Title	Function	Legal Values
Connections		
Port	Specify which port the device is connected to the Fieldserver	P1-P8, R1-R2 ¹
Protocol	Specify protocol used	GE MKIV
Baud*	Specify baud rate	300; 1200; 2400; 4800; 9600 ; 19200; 28800; 38400
Parity*	Specify parity	Even
Data_Bits*	Specify data bits	8
Stop_Bits*	Specify stop bits	1
Poll_Delay*	Time between internal polls	0-32000s, 1.0s

Example

```

//      Client Side Connections

Connections
Port   , Protocol   , Baud   , Parity  , Poll_Delay
P1     , GE MKIV    , 9600   , Even   , 0.100s
```

¹ Not all ports shown are necessarily supported by the hardware. Consult the appropriate Instruction manual for details of the ports available on specific hardware.

5.2 Client Side Node Descriptors

Section Title		
Nodes		
Column Title	Function	Legal Values
Node_Name	Provide name for node	Up to 32 alphanumeric characters
Protocol	Specify protocol used	GE MKIV
Port	Specify which port the device is connected to the Fieldserver	P1-P8, R1-R2 ²

Example

```
// Client Side Nodes

Nodes
Node_Name , Protocol , Port
GE_Node_1 , GE MKIV , P1
```

5.3 Client Side Map Descriptors

5.3.1 FieldServer Related Map Descriptor Parameters

Column Title	Function	Legal Values
Map_Descriptor_Name	Name of this Map Descriptor	Up to 32 alphanumeric characters
Data_Array_Name	Name of Data Array where data is to be stored in the Fieldserver	One of the Data Array names from Section 4.
Data_Array_Offset	Starting location in Data Array	0 to (Data_Array_Length-1) as specified in Section 4.
Function	Function of Client Map Descriptor	Passive

5.3.2 Driver Related Map Descriptor Parameters

Column Title	Function	Legal Values
Node_Name	Name of Node to fetch data from	One of the Node names specified in Section 5.2
Length	Length of Map Descriptor	253
Address	Starting address of read block	1

² Not all ports shown are necessarily supported by the hardware. Consult the appropriate Instruction manual for details of the ports available on specific hardware.

5.3.3 Map Descriptor Example.

```
// Client Side Map Descriptors

Map_Descriptors
Map_Descriptor_Name , Data_Array_Name , Data_Array_Offset , Function , Node_Name , Address , Length
Status_Data_1 , GE_Status_Data , 0 , Passive , GE_Node_1 , 1 , 253
```

Use any descriptive name.

Received status data will be stored in this data array. Must be previously declared in Section 4.

Received data will be stored in the data array starting at this offset. Use zero to store data from the very first data array location.

This driver can only be used as a passive client listening for Speedtronic status data.

This Map Descriptor will only respond to the node settings defined under the Section 5.2.

The starting address of received data to be stored must always start at 1 for this driver, since received data is always a complete dump of all statuses.

The length of the data this Map Descriptor will store. The complete status dump from the Speedtronic is 253 bytes long.

Appendix A. Reference

Appendix A.1. Driver Point List

Byte No.	Signal	Description	Zero Pt.	Maximum	Units	Bytes
Miscellaneous Points						
1	TIME	SECONDS	0	59		1
2	TIME	MINUTES	0	59		1
3	TIME	HOUR	0	24		1
4	TIME	DAY	0	9		1
5	TIME	MONTH	0	12		1
6	TIME	YEAR	0	99		1
7	TIMR-01	TOTAL FIRED HOURS	0	9999999.9		4
11	TIMR-02	MANUALLY INIT STARTS	0	9999999.9		4
15	CNTR-01	PEAK FIRED HOURS	0	9999999.9		4
19	CNTR-02	TOTAL STARTS	0	9999999.9		4
23	CNTR-03	FAST LOAD STARTS	0	9999999.9		4
27	CNTR-04	FIRED STARTS	0	9999999.9		4
31	CNTR-05	TRIPS	0	9999999.9		4
Integer Points						
35	TTX01-1	EXHAUST TEMPERATURE TC = 1	0	2048	DEG F	2
37	TTX01-2	EXHAUST TEMPERATURE TC = 2	0	2048	DEG F	2
39	TTX01-3	EXHAUST TEMPERATURE TC = 3	0	2048	DEG F	2
41	TTX01-4	EXHAUST TEMPERATURE TC = 4	0	2048	DEG F	2
43	TTX01-5	EXHAUST TEMPERATURE TC = 5	0	2048	DEG F	2
45	TTX01-6	EXHAUST TEMPERATURE TC = 6	0	2048	DEG F	2
47	TTX01-7	EXHAUST TEMPERATURE TC = 7	0	2048	DEG F	2
49	TTX01-8	EXHAUST TEMPERATURE TC = 8	0	2048	DEG F	2
51	TTX01-9	EXHAUST TEMPERATURE TC = 9	0	2048	DEG F	2
53	TTX01-10	EXHAUST TEMPERATURE TC = 10	0	2048	DEG F	2
55	TTX01-11	EXHAUST TEMPERATURE TC = 11	0	2048	DEG F	2
57	TTX01-12	EXHAUST TEMPERATURE TC = 12	0	2048	DEG F	2
59	TTX01-13	EXHAUST TEMPERATURE TC = 13	0	2048	DEG F	2
61	TTX01-14	EXHAUST TEMPERATURE TC = 14	0	2048	DEG F	2
63	TTX01-15	EXHAUST TEMPERATURE TC = 15	0	2048	DEG F	2
65	TTX01-16	EXHAUST TEMPERATURE TC = 16	0	2048	DEG F	2
67	TTX01-17	EXHAUST TEMPERATURE TC = 17	0	2048	DEG F	2
69	TTX01-18	EXHAUST TEMPERATURE TC = 18	0	2048	DEG F	2
71	TTXC	EX TEMP AVG LOW'S - HIGH AND LOW REJECTED	0	2048	DEG F	2
73	CTIF-1	COMP INLET FLANGE TEMP 1	0	2048	DEG F	2
75	CTIF-2	COMP INLET FLANGE TEMP 2	0	2048	DEG F	2
77	CTDA-1	COMP DISCHARGE TEMP 1	0	2048	DEG F	2
79	CTDA-2	COMP DISCHARGE TEMP 2	0	2048	DEG F	2
81	TTWS1FI1	TURB WHEELSPACE TEMP 1ST STG FWD INNER	0	2048	DEG F	2
83	TTWS1FI2	TURB WHEELSPACE TEMP 1ST STG FWD INNER	0	2048	DEG F	2
85	TTWS1FO1	TURB WHEELSPACE TEMP 1ST STG FWD OUTER	0	2048	DEG F	2
87	TTWS1FO2	TURB WHEELSPACE TEMP 1ST STG FWD OUTER	0	2048	DEG F	2
89	TTWS1FA1	TURB WHEELSPACE TEMP 1ST STG AFT OUTER	0	2048	DEG F	2
91	TTWS1FA2	TURB WHEELSPACE TEMP 1ST STG AFT OUTER	0	2048	DEG F	2

Byte No.	Signal	Description	Zero Pt.	Maximum	Units	Bytes
93	TTWS2FO1	TURB WHEELSPACE TEMP 2ND STG FWD INNER	0	2048	DEG F	2
95	TTWS2FO2	TURB WHEELSPACE TEMP 2ND STG FWD INNER	0	2048	DEG F	2
97	TTWS2AO1	TURB WHEELSPACE TEMP 2ND STG AFT OUTER	0	2048	DEG F	2
99	TTWS2AO2	TURB WHEELSPACE TEMP 2ND STG AFT OUTER	0	2048	DEG F	2
101	TTWS3FO1	TURB WHEELSPACE TEMP 3RD STG FWD INNER	0	2048	DEG F	2
103	TTWS3FO2	TURB WHEELSPACE TEMP 3RD STG FWD INNER	0	2048	DEG F	2
105	TTWS3AO1	TURB WHEELSPACE TEMP 3RD STG AFT OUTER	0	2048	DEG F	2
107	TTWS3AO2	TURB WHEELSPACE TEMP 3RD STG AFT OUTER	0	2048	DEG F	2
109	TTXSPL	COMBUSTION MONITOR ALLOWABLE SPREAD	0	2048	DEG F	2
111	TTXSP1	COMBUSTION MONITOR ACTUAL SPREAD 1	0	2048	DEG F	2
113	TTXSP2	COMBUSTION MONITOR ACTUAL SPREAD 2	0	2048	DEG F	2
115	LTTH1	LUBE TEMP TURBINE HEADER, GT/GG	0	2048	DEG F	2
117	LTB1D	LUBE TEMP NO. 1 TURB. BRG. DRAIN	0	2048	DEG F	2
119	LTB2D	LUBE TEMP NO. 2 TURB. BRG. DRAIN	0	2048	DEG F	2
121	LTBT1D	LUBE TEMP NO. 1 THRUST BRG. DRAIN	0	2048	DEG F	2
123	BTLG1	BEARING METAL TEMP LEAD GEAR =1	0	2048	DEG F	2
125	BTLG2	BEARING METAL TEMP LEAD GEAR =2	0	2048	DEG F	2
127	BTLG3	BEARING METAL TEMP LEAD GEAR =3	0	2048	DEG F	2
129	BTLG4	BEARING METAL TEMP LEAD GEAR =4	0	2048	DEG F	2
131	BTLG5	BEARING METAL TEMP LEAD GEAR =5	0	2048	DEG F	2
133	BTGJ11	BEARING METAL TEMP GEN. JOURNAL =1	0	2048	DEG F	2
135	BTGJ21	BEARING METAL TEMP GEN. JOURNAL =2	0	2048	DEG F	2
137	BB1	VIBRATION TRANSDUCER = 1	0	8	IN/SEC	2
139	BB2	VIBRATION TRANSDUCER = 2	0	8	IN/SEC	2
141	BB4	VIBRATION TRANSDUCER = 4	0	8	IN/SEC	2
143	BB5	VIBRATION TRANSDUCER = 5	0	8	IN/SEC	2
145	BB7	VIBRATION TRANSDUCER = 7	0	8	IN/SEC	2
147	BB8	VIBRATION TRANSDUCER = 8	0	8	IN/SEC	2
149	BB9	VIBRATION TRANSDUCER = 9	0	8	IN/SEC	2
151	BB-MAX	VIBRATION MAX SELECT	0	8	IN/SEC	2
153	PN	TURBINE STARTING DEVICE SPEED	0	125	% SPEED	2
155	TNH	TURBINE SPEED HP	0	125	% SPEED	2
157	TNR	SPEED CONTROL REFERENCE	0	125	% SPEED	2
159	FSR1	LIQUID FUEL STROKE REF. FROM FUEL SPLITTER	1	100	%	2
161	FSR2	GAS FUEL STROKE REF. FROM FUEL SPLITTER	1	100	%	2
163	CPD	COMPRESSOR DISCHARGE PRESSURE	0	2048	PSI	2
165	FPCI	INTERVALVE PRESSURE	0	2048	PSI	2
167	TTRXB	SPEED BIASED TEMPERATURE CONTROL REF.	0	2048	DEG F	2
169	CSRGV	VIGV REFERENCE ANGLE	0	100	DEGR	2
171	CSGV	INLET GUIDE VANE ANGLE (SCALED)	0	100	DEGR	2
173	FOROUT	LIQUID FUEL FLOW REFERENCE	0	10	V DC	2
175	FO	LIQUID FUEL FLOW	0	64	m/SEC	2
177	FSROUT	GAS CONTROL VALVE POSITION REFERENCE	0	10	V DC	2
179	FSG	GAS CONTROL VALVE LVDT POSITION	0	100	%	2
181	FPRG	GAS RATIO VALVE CONTROL PRESS REF.	0	10	V DC	2
183	FSGR	SPEED RATIO VALVE CALIBR. POS.	0	10	V DC	2
185	DW	GENERATOR LOAD	0.00	204.80	MW	2
187	SVL	SYSTEM LINE VOLTAGE	0	150	V RMS	2
189	SFL	SYSTEM LINE FREQUENCY	0.00	62.50	HZ	2

Byte No.	Signal	Description	Zero Pt.	Maximum	Units	Bytes
191	DVAR	GENERATOR LOAD VARS (SCALED)	0.00	204.80	MVAR	2
193	DDUMP1	SPARE POINT (OPT. WRITTEN TO BY SEQUENCING)	0	32768	CNT1S	2
195	DDUMP2		0	32768	CNT1S	2
197	DDUMP3		0	32768	CNT1S	2
199	DDUMP4		0	32768	CNT1S	2
201	DDUMP5		0	32768	CNT1S	2
203	DDUMP6		0	32768	CNT1S	2
205	DDUMP7		0	32768	CNT1S	2
207	DDUMP8		0	32768	CNT1S	2
207	DDUMP8		0	32768	CNT1S	2

Byte No.	Signal	Description	Logic Zero	Logic One	Bytes	
Logic points						
211	0	L30D-SD	NORMAL DISPLAY MESSAGE "SHUTDOWN STATUS"	0	1	1/8
	1	L30D-SU	NORMAL DISPLAY MESSAGE "STARTUP STATUS"	0	1	1/8
	2	L30D-RUN	NORMAL DISPLAY MESSAGE "RUN STATUS"	0	1	1/8
	3	L30D-RSZ	NORMAL DISPLAY MESSAGE "NOT READY TO START"	0	1	1/8
	4	L30D-RSZ	NORMAL DISPLAY MESSAGE "READY TO START"	0	1	1/8
	5	L30D-STG	NORMAL DISPLAY MESSAGE "STARTING"	0	1	1/8
	6	L30D-CRN	NORMAL DISPLAY MESSAGE "CRANKING"	0	1	1/8
212	7	L63SUF 1	STARTUP FSR FIRING FUEL COMMAND	0	1	1/8
	0		STARTUP FSR WARMUP FUEL COMMAND	0	1	1/8
	1		NORMAL DISPLAY MESSAGE "ACCELERATING"	0	1	1/8
	2		NORMAL DISPLAY MESSAGE "FULL SPEED NO LOAD"	0	1	1/8
	3		NORMAL DISPLAY MESSAGE "SYNCHRONIZING"	0	1	1/8
	4		NORMAL DISPLAY MESSAGE "SPINNING RESERVE"	0	1	1/8
	5		NORMAL DISPLAY MESSAGE "LOADING"	0	1	1/8
213	6		NORMAL DISPLAY MESSAGE "FAST LOADING"	0	1	1/8
	7		NORMAL DISPLAY MESSAGE "PRESELECTED LOAD"	0	1	1/8
	0		NORMAL DISPLAY MESSAGE "BASE LOAD"	0	1	1/8
	1		NORMAL DISPLAY MESSAGE "PEAK LOAD"	0	1	1/8
	2		NORMAL DISPLAY MESSAGE "PART LOAD"	0	1	1/8
	3		NORMAL DISPLAY MESSAGE "UNLOADING"	0	1	1/8
	4		NORMAL DISPLAY MESSAGE "FIRED SHUTDOWN"	0	1	1/8
214	5		NORMAL DISPLAY MESSAGE "COASTING DOWN"	0	1	1/8
	6		NORMAL DISPLAY MESSAGE "ON COOLDOWN"	0	1	1/8
	7		NORMAL DISPLAY MESSAGE "OFF COOLDOWN"	0	1	1/8
	0		OFF MODE SELECTED	0	1	1/8
	1		CRANK MODE SELECTED	0	1	1/8
	2		FIRE MODE SELECTED	0	1	1/8
	3		AUTO MODE SELECTED	0	1	1/8
215	4		REMOTE MODE SELECTED	0	1	1/8
	5		NORMAL DISPLAY MESSAGE "START SELECT"	0	1	1/8
	6		NORMAL DISPLAY MESSAGE "STOP SELECT"	0	1	1/8
	7		PRE-SELECTED LOAD COMMAND	0	1	1/8
215	0		BASE LOAD COMMAND	0	1	1/8
	1		PEAK LOAD COMMAND	0	1	1/8
	2		FSR SHUTDOWN CONTROL	0	1	1/8
	3		FSR STARTUP CONTROL	0	1	1/8

Byte No.	Signal	Description	Logic Zero	Logic One	Bytes
Logic points					
	4	FSR ACCELERATION CONTROL HP SPEED	0	1	1/8
	5	FSR TEMPERATURE CONTROL	0	1	1/8
	6	FSR SPEED DROOP CONTROL	0	1	1/8
	7	FSR SPEED ISOCH CONTROL	0	1	1/8
216	0	MIN FSR LOGIC	0	1	1/8
	1	FSR MANUAL CONTROL	0	1	1/8
	2	SEQUENCE IN PROGRESS	0	1	1/8
	3	10V CONTROL MESSAGE - MAXIMUM ANGLE	0	1	1/8
	4	10V CONTROL MESSAGE - TEMPERATURE CONTROL	0	1	1/8
	5	10V CONTROL MESSAGE - MANUAL CONTROL	0	1	1/8
	6	NORMAL DISPLAY MESSAGE "VOLTAGE MATCHING"	0	1	1/8
	7	AUXILIARY TO FAST LOAD START SIGNAL	0	1	1/8
217	0	WATER WASH SELECTED	0	1	1/8
	1	FUEL LINE PURGE IN PROGRESS	0	1	1/8
	2	MASTER PROTECTIVE SIGNAL	0	1	1/8
	3	NORMAL SHUTDOWN	0	1	1/8
	4	TURBINE COMPLETE SEQUENCE	0	1	1/8
	5	HP ZERO SPEED SIGNAL	0	1	1/8
	6	MINIMUM SPEED SIGNAL (APPR 20%)	0	1	1/8
	7	ACCELERATING FUEL SPEED SIGNAL (APPR 40%)	0	1	1/8
218	0	HP OPERATING SPEED SIGNAL	0	1	1/8
	1	FLAME DETECTED CHANNEL =1	0	1	1/8
	2	FLAME DETECTED CHANNEL =2	0	1	1/8
	3	FLAME DETECTED CHANNEL =3	0	1	1/8
	4	FLAME DETECTED CHANNEL =4	0	1	1/8
	5	GENERATOR BREAKER CLOSURE	0	1	1/8
	6	SPARE POINT (OPT. WRITTEN TO BY SEQUENCING)	0	1	1/8
	7		0	1	1/8
219	0	SPARE POINT (OPT. WRITTEN TO BY SEQUENCING)	0	1	1/8
	1		0	1	1/8
	2		0	1	1/8
	3		0	1	1/8
	4		0	1	1/8
	5		0	1	1/8
	6		0	1	1/8
	7		0	1	1/8
220	0	SPARE POINT (OPT. WRITTEN TO BY SEQUENCING)	0	1	1/8
	1		0	1	1/8
	2		0	1	1/8
	3		0	1	1/8
	4		0	1	1/8
	5		0	1	1/8
	6		0	1	1/8
	7		0	1	1/8
221	0	SPARE POINT (OPT. WRITTEN TO BY SEQUENCING)	0	1	1/8
	1		0	1	1/8
	2		0	1	1/8
	3		0	1	1/8
	4		0	1	1/8

Byte No.	Signal	Description	Logic Zero	Logic One	Bytes
Logic points					
	5		0	1	1/8
	6		0	1	1/8
	7		0	1	1/8

Byte No.	Description	LogicZero	LogicOne	Bytes
Annunciator Alarms				
222	ALARM 0-7	0	FF	1
223	ALARM 8-15	0	FF	1
224	ALARM 16-23	0	FF	1
225	ALARM 24-31	0	FF	1
226	ALARM 32-39	0	FF	1
227	ALARM 40-47	0	FF	1
228	ALARM 48-55	0	FF	1
229	ALARM 56-63	0	FF	1
230	ALARM 64-71	0	FF	1
231	ALARM 72-79	0	FF	1
232	ALARM 80-87	0	FF	1
233	ALARM 88-95	0	FF	1
234	ALARM 96-103	0	FF	1
235	ALARM 104-111	0	FF	1
236	ALARM 112-119	0	FF	1
237	ALARM 120-127	0	FF	1
238	ALARM 128-135	0	FF	1
239	ALARM 136-143	0	FF	1
240	ALARM 144-151	0	FF	1
241	ALARM 152-159	0	FF	1
242	ALARM 160-167	0	FF	1
243	ALARM 168-175	0	FF	1
244	ALARM 176-183	0	FF	1
245	ALARM 184-191	0	FF	1
246	ALARM 192-199	0	FF	1
247	ALARM 200-207	0	FF	1
248	ALARM 208-215	0	FF	1
249	ALARM 216-223	0	FF	1
250	ALARM 224-231	0	FF	1
251	ALARM 232-239	0	FF	1
252	ALARM 240-247	0	FF	1
253	ALARM 248-255	0	FF	1